

# Technical Description

## Swivel tool changer STC100

M0413-1

Tool changers | Swivels | **Swivel tool changers** | Grippers | Hose packages | Valve units | Tool systems





The information in this document is subject to change without prior notice and should not be regarded as an undertaking from Robot System Products AB. Robot System Products AB assumes no responsibility for errors that may occur in this document.

Robot System Products AB bears no responsibility for damage that is incurred by the use of this document, or the software or hardware described in this document.

The document, or parts of it, may not be reproduced or copied without prior permission from Robot System Products AB. It may neither be imparted to a third party, nor otherwise be used without authorization. Infringement hereof will be subject to action in accordance with the applicable laws.

Further copies of this document can be obtained from Robot System Products AB at current prices.

© Robot System Products AB

Robot Systems Products AB  
Isolatorvägen 4  
SE-721 37 Västerås  
Sweden

# CONTENTS

<b>1 INTRODUCTION .....</b>	<b>5</b>
1.1 RSP swivel tool changer .....	6
1.2 Documents .....	6
1.3 Wear parts.....	6
1.4 Complementary Equipment .....	6
<b>2 TECHNICAL SPECIFICATIONS .....</b>	<b>7</b>
2.1 Description of swivel tool changers and tool attachments .....	7
2.1.1 Coordinate System Definition .....	8
2.1.2 Swivel tool changer STC100-6. Article no: P1908.....	9
2.1.3 Swivel tool changer STC100-2. Article no: P1910.....	10
2.1.4 Tool attachment, TA100-8. Article: P0407 .....	11
2.1.5 Square tool attachment, TA100-8. Article no: P0402 .....	12
2.1.6 Swivel tool changer STC100-6E. Article no: P1907 .....	13
2.1.7 Swivel tool changer STC100-6E sealed. Article no: P1915.....	14
2.1.8 Swivel tool changer STC100-2E. Article no: P1909 .....	15
2.1.9 Swivel tool changer STC100-2E sealed. Article no: P1916.....	16
2.1.10 Tool attachment, TA100-8E. Article no: P0409 .....	17
2.1.11 Tool attachment, TA100-8E. Article no: P0418 .....	18
2.1.12 Square tool attachment, TA100-8E. Article no: P0404.....	19
2.1.13 Square tool attachment, TA100-8E. Article no: P0474.....	20
2.1.14 Pneumatic diagram STC100-6 and STC100-6E.....	21
2.1.15 Pneumatic diagram STC100-2 and STC100-2E.....	21
2.1.16 Circuit diagram E0199-002 for P1907, P1915, P1909 and P1916.....	22
2.2 Options for swivel tool changer.....	23
2.2.1 Robot adaptation kit .....	23
2.2.2 Tool Identification .....	23
2.2.3 Tool stand kit. Article no: P0423 .....	24
2.2.4 Limitation of Robot movements .....	24
<b>3 SPARE PARTS.....</b>	<b>25</b>
3.1 Part list for swivel tool changer P1908, P1907 and P1915 .....	25
3.2 Part list for swivel tool changer P1910, P1909 and P1916 .....	26

# 1 INTRODUCTION

**Robot System Products** is a front-rank provider of peripheral products for high performance robot applications. We provide complete system solutions for your robot installations, aiming to improve your productivity with the most reliable and cost-effective tooling on the market. Continuously we explore emerging technologies, working with leading edge design.

**Robot System Products** has a wide range of standard robot peripheral products:

- Tool changers
- Swivels
- Swivel tool changers
- CiRo
- Grippers
- Hose Packages
- Valve units
- Tool systems
- Tool parking systems

**Robot System Products'** tool changers are constructed to maximize the flexibility and reliability of your robot fleet. Through our patented locking device TrueConnect™ robustness and high safety are combined with low weight and compactness. With our swivels compressed air, water, electrical and data signals as well as weld and servo power are transferred to your tools with robot motion capabilities fully maintained. Our swivel tool changers unite the TrueConnect™ mechanism with our swivel technology, combining the best out of the two technologies. With RSP's cost-effective CiRo, cables and hoses can be freely selected with high robot flexibility maintained, and space requirements reduced. Our integrated tool systems are delivered as complete plug-and-play solutions designed for quick and simple installation.

**Robot System Products'** product lines are available for all major robot brands and come with complete documentation. 3D-models for simulation are available for download at: [www.rsp.eu.com](http://www.rsp.eu.com).

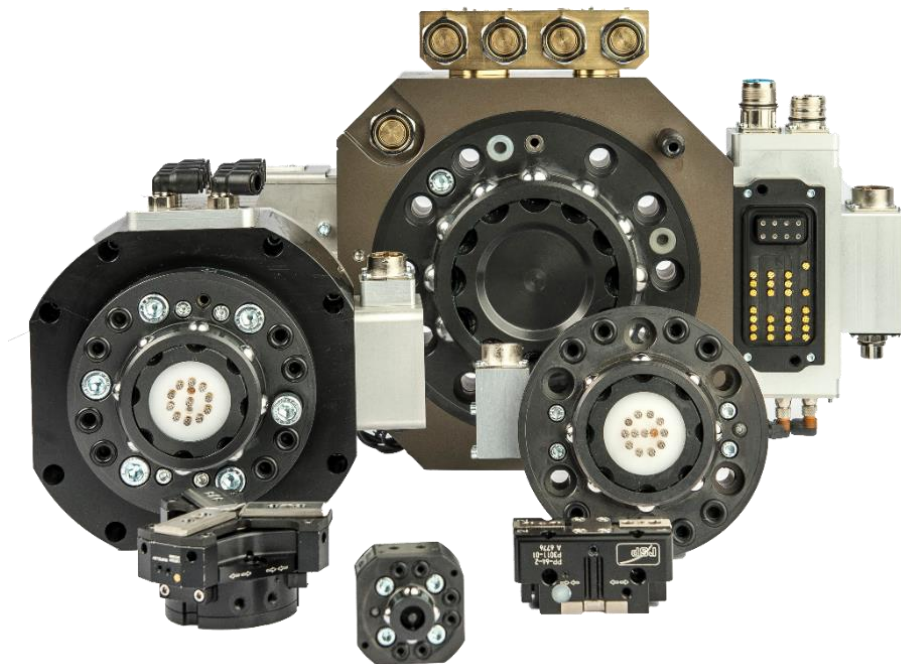

## 1.1 RSP swivel tool changer

The Robot System Products' swivel tool changer integrates the advantages of swivels and tool changers into one single product maximizing the flexibility and productivity of the robot.

Our tool changer technology enables robots to handle and switch between multiple tools. The principle behind the patented locking device TrueConnect™ is that load is distributed uniformly through pressing locking balls into spherical grooves in the tool attachment. With TrueConnect™ the play is a minimum and the position repeatability is practically absolute through the lifespan. In consequence substantially larger positional deviations are accepted when docking, A built-in spring ensures that the tool remains in place in the swivel tool changer even if the air pressure drops.

When using a swivel tool changer compressed air and electric signals will be directly available at the tool without loose, hanging cables and hoses which has to be considered during programming. The combination of RSP's hose packages with the swivel tool changer does in addition significantly reduce the design and installation times for the system integrator.

## 1.2 Documents

This *Technical Description* contains product information and data, drawings, circuit and pneumatic diagrams and lists of spare parts. In the document *Installation and Maintenance* (M0412-1) procedures for mounting, installation and replacement of equipment are described together with descriptions of inspection, cleaning and lubrication activities including recommended maintenance intervals.

## 1.3 Wear parts

Wear parts should be replaced before considerable damage occurs. The interval depends on the number of tool changes and its working environment. Generally, the more contaminated environment, the closer maintenance intervals.

The following parts are considered as wear parts:

- Signal pins
- Air sealings
- O-rings

## 1.4 Complementary Equipment

Complementary equipment is described in separate documents.

Article	Note
External valve units	Mounted at the rear of the upper arm. Shuts off the air automatically during tool changing.
Cable and Hose Package	Complete packages for most robots on the market ready to be mounted without any modifications.
Tool parking systems	RSP tool parking systems give rigid installations for easy tool changing.
Connection kits	Connection kits for tool changers and tool attachments simplifying electrical installations.
3D-models	Available in Solid Works®, STEP, X_T and IGES-format.

## 2 TECHNICAL SPECIFICATIONS

### 2.1 Description of swivel tool changers and tool attachments

This document presents the Robot System Products STC100-6, STC100-2, STC100-6E and STC100-2E swivel tool changers including tool attachments dedicated for material handling. Likewise presented are adaptation kits, connection kits to facilitate electrical installation and a tool stand kit.

The swivel tool changers STC100-6 and STC100-2 transfers compressed air to the tool. They can be equipped with transfer of electrical signals, via spring loaded signal pins, to the tool attachment. The electrical versions are designated 'E'. The swivel tool changers STC100-6, STC100-2, STC100-6E, STC100-2E cannot transport fluids. Sealed versions are ingress protected according to IP65.

The spring-loaded signal pins of STC100-6E, STC100-2E are placed and protected along a circle close to the centre of the swivel tool changer. The signal pins are not in connection until at the very end of the docking cycle when the tool attachment is already properly aligned. This guarantees a minimum of wear of pins and contact surfaces. A built-in inductive sensor can be used for checking that the tool changer is in open position. Locking of tool changer and presence of tool attachment can be checked through a built-in signal jumper.

For other bolt circles adaptation plates between the swivel tool changer and the turning disc on the robot may be needed. Such adaptation plates are available from RSP.



**STC100-6E**

## 2.1.1 Coordinate System Definition

A swivel tool changer adds load to the robot. If the arm and tool loads are not stated correctly during programming the behaviour of the robot and the wear of the equipment will be affected. Information about weight and centre of gravity can, in accordance with the co-ordinate system stated below, be found in the technical specification tables of the swivel tool changers.

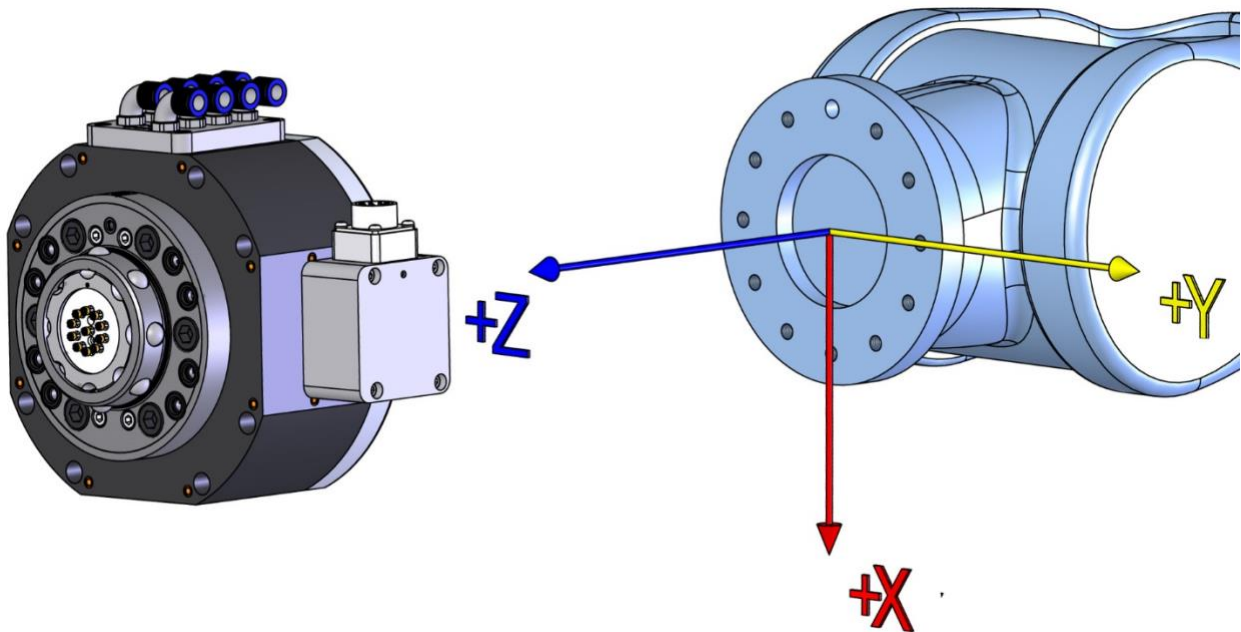

**NOTE!** For the tool changer and tool changer with tool attachment, the origin of the co-ordinate system is situated in the centre of the robot mounting flange.



## 2.1.2 Swivel tool changer STC100-6. Article no: P1908

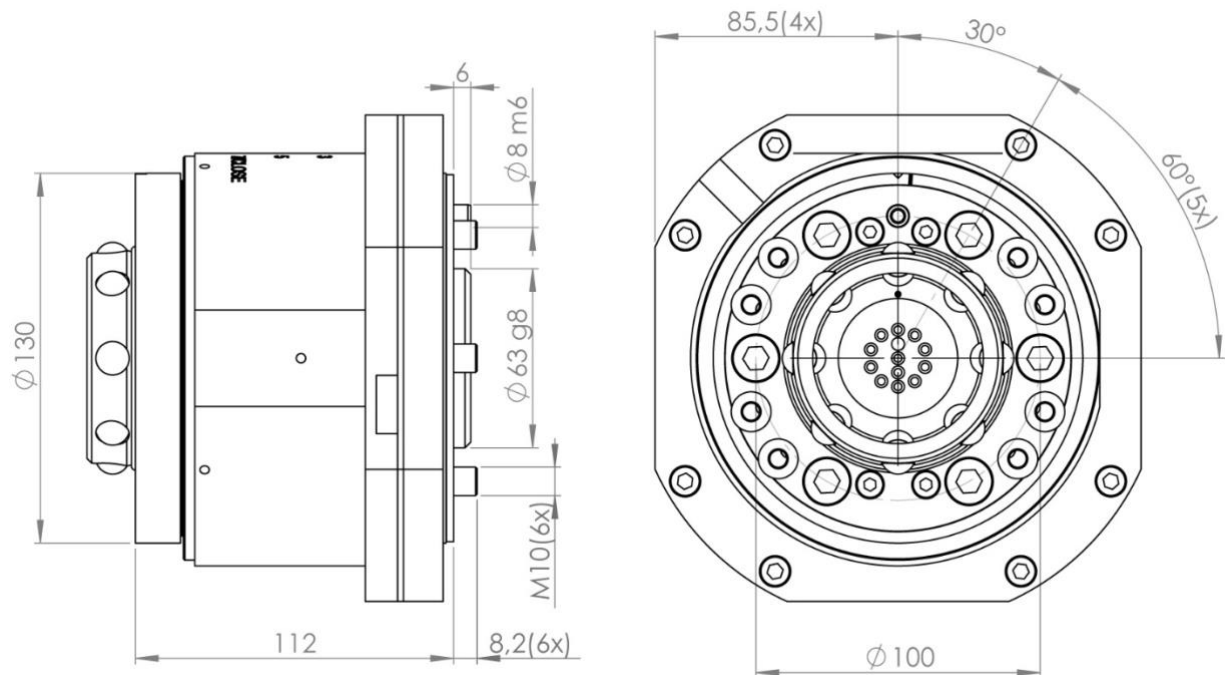

Swivel tool changer STC100-6 transfers 6 pneumatic channels to the tool attachment and has separate inlets for Open TC and Close TC. To be used together with P0407 or P0402.

### Technical data

<b>Working temperature</b>		+10°C--+50°C
<b>Bolt pattern</b>		ISO 9409-1 100-6-M10
<b>IP classification</b>		IP 54
<b>Maximum tool load</b>	Fz (static)	±1 000 N
	Mx/My (dynamic)	±1 000 Nm
	Mz (dynamic)	±1 000 Nm
<b>Weight and centre of gravity (Z)</b>		
P1908		5.6 kg / 65 mm
P1908 with P0407		7.1 kg / 77 mm
P1908 with P0402		7.7 kg / 83 mm
<b>Rotational torque</b>		45 Nm
<b>Air channels</b>	Pneumatic diagram	See section 2.1.14
	User channels, robot side	6 x G 1/8" (800 l/min, max 10 bar)
	Dedicated channels, G 1/8"	Open TC marked 8/OPEN. Close TC marked 7/CLOSE (6-10 bar)
	Air quality	Oil-clean and waterless filtered air, with max 25µm particle content

### 2.1.3 Swivel tool changer STC100-2. Article no: P1910

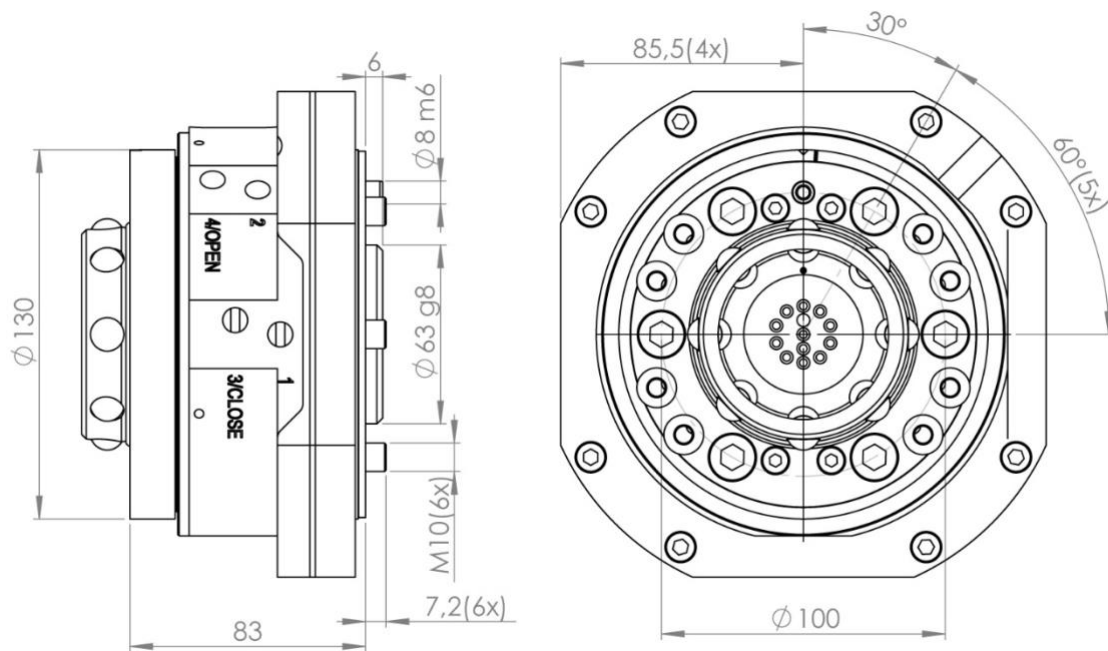

Swivel tool changer STC100-2 transfers 2 pneumatic channels to the tool attachment and has separate inlets for Open TC and Close TC. To be used together with P0407 or P0402.

#### Technical data

<b>Working temperature</b>		+10°C–+50°C
<b>Bolt pattern</b>		ISO 9409-1 100-6-M10
<b>IP classification</b>		IP 54
<b>Maximum tool load</b>	Fz (static)	±1 000 N
	Mx/My (dynamic)	±1 000 Nm
	Mz (dynamic)	±1 000 Nm
<b>Weight and centre of gravity (Z)</b>		
P1910		4.8 kg / 49 mm
P1910 with P0407		6.3 kg / 60 mm
P1910 with P0402		6.9 kg / 66 mm
<b>Rotational torque</b>		35 Nm
<b>Air channels</b>	Pneumatic diagram	See section 2.1.15
	User channels, robot side Dedicated channels, G 1/8"	2 x G 1/8" (800 l/min, max 10 bar) Open TC marked 4/OPEN. Close TC marked 3/CLOSE (6-10 bar)
	Air quality	Oil-clean and waterless filtered air, with max 25µm particle content

## 2.1.4 Tool attachment, TA100-8. Article: P0407

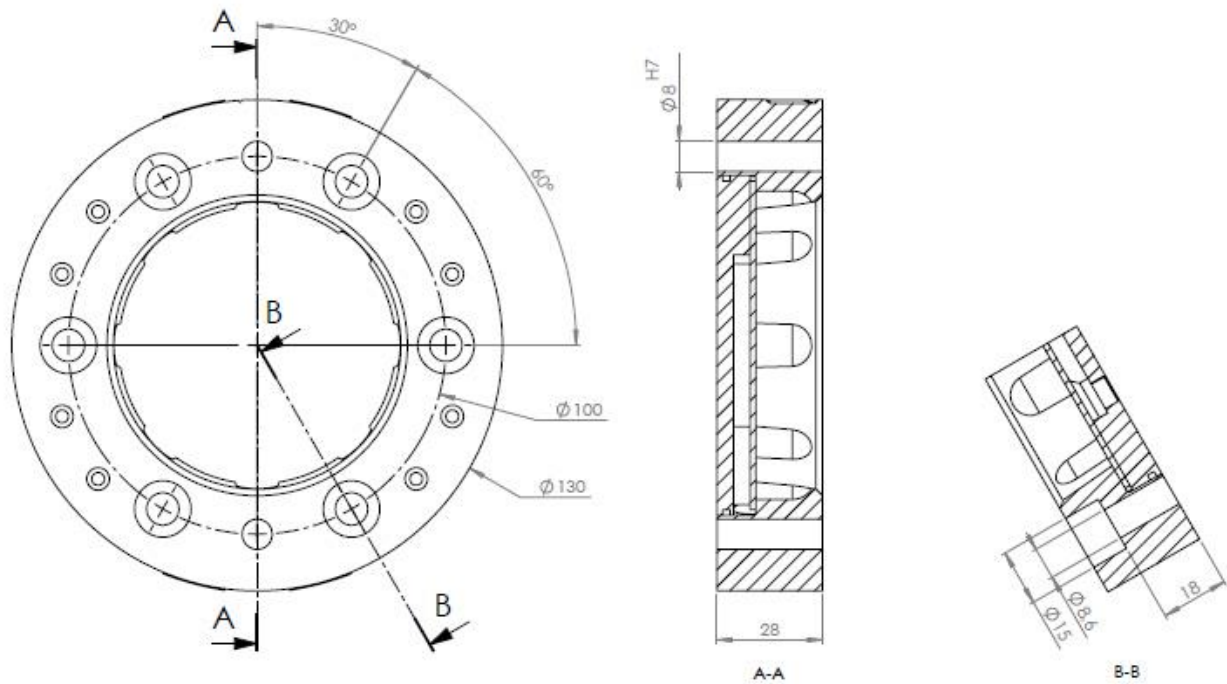

Tool attachment TA 100-8 transfers 8 pneumatic channels to the tool. To be used together with P1908 or P1910.

### Technical data

<b>Working temperature</b>		+10°C–+50°C
<b>Bolt pattern</b>		ISO9409-1-100-6-M8
<b>Weight</b>		1.5 kg
<b>Maximum tool load</b> (screw class 8.8)	Fz (static)	±1 000 N
	Mx/My (dynamic)	±1 000 Nm
	Mz (dynamic)	±600 Nm
<b>Maximum tool load</b> (screw class 12.9)	Fz (static)	±1 000 N
	Mx/My (dynamic)	±1 000 Nm
	Mz (dynamic)	±1 000 Nm
<b>Air channels</b>	Connection, tool side	8 x G 1/8"



### NOTE!

The tool attachment shall be mounted to the tool using six M8-screws.

## 2.1.5 Square tool attachment, TA100-8. Article no: P0402

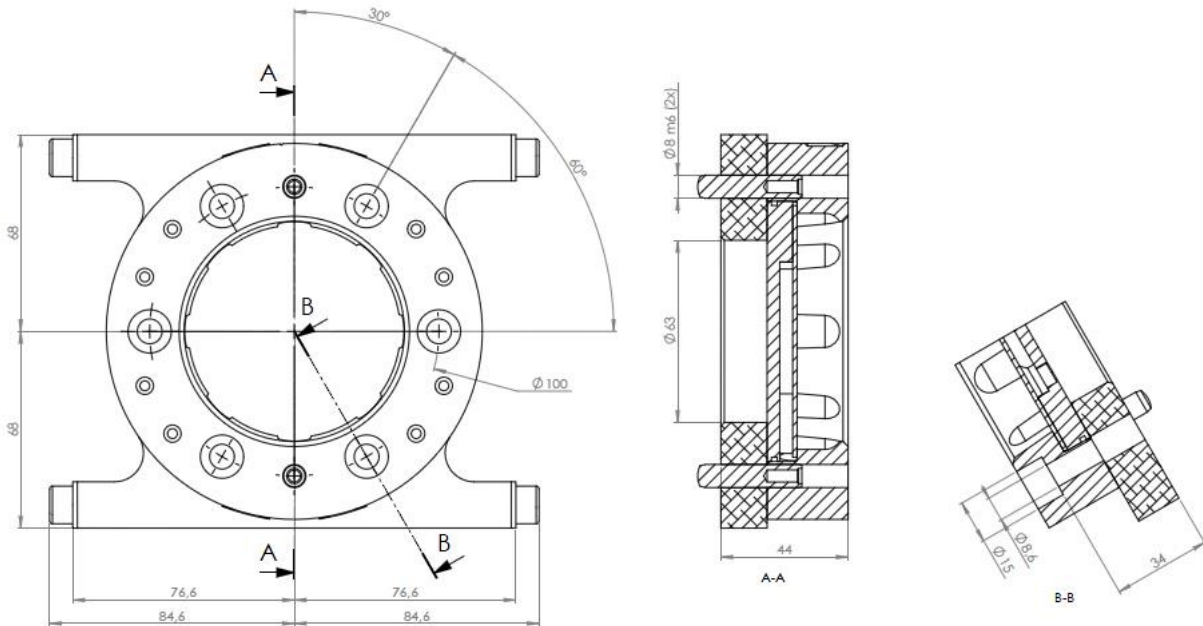

Square tool attachment TA 100-8 transfers 8 pneumatic channels to the tool and gives together with option P0423 a stable tool stand for easy tool changing. To be used together with P1908 or P1910.

### Technical data

<b>Working temperature</b>		+10°C–+50°C
<b>Bolt pattern</b>		ISO9409-1-100-6-M8
<b>Weight</b>		2.2 kg
<b>Maximum tool load</b> (screw class 8.8)	Fz (static)	±1 000 N
	Mx/My (dynamic)	±1 000 Nm
	Mz (dynamic)	±600 Nm
<b>Maximum tool load</b> (screw class 12.9)	Fz (static)	±1 000 N
	Mx/My (dynamic)	±1 000 Nm
	Mz (dynamic)	±1 000 Nm
<b>Air channels</b>	Connection, tool side	8 x G 1/8"



### NOTE!

The tool attachment shall be mounted to the tool using six M8-screws.

## 2.1.6 Swivel tool changer STC100-6E. Article no: P1907

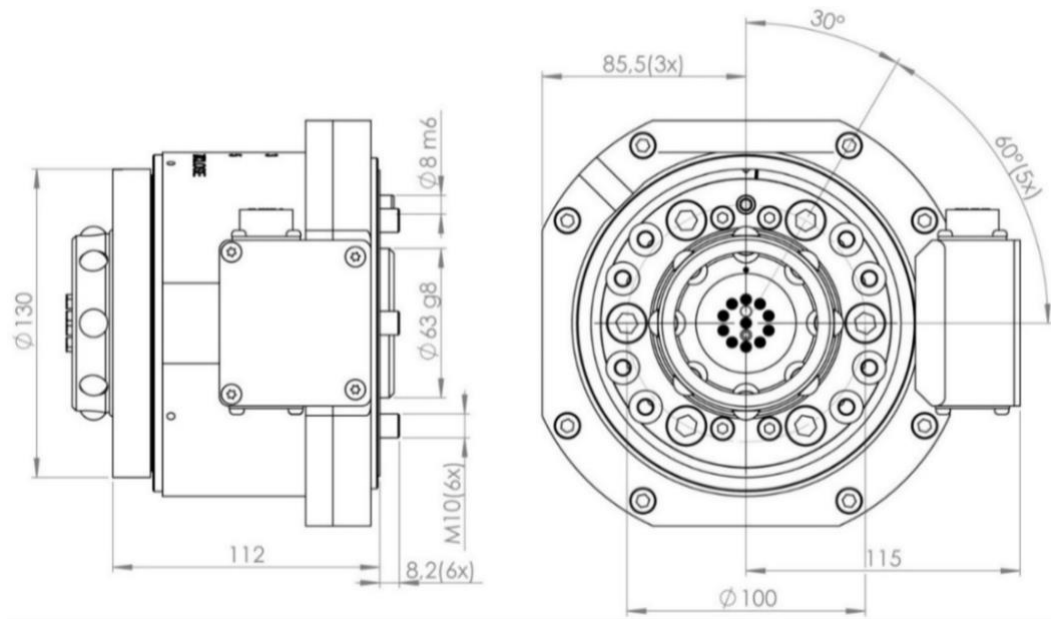

Swivel tool changer STC100-6E transfers 6 pneumatic channels and 12 electrical signals to the tool attachment and has separate inlets for Open TC and Close TC. To be used together with P0409, P0404, P0418 or P0474.

### Technical data

<b>Working temperature</b>		+10°C–+50°C
<b>Bolt pattern</b>		ISO 9409-1 100-6-M10
<b>IP classification</b>		IP 54
<b>Maximum tool load</b>	Fz (static)	±1 000 N
	Mx/My (dynamic)	±1 000 Nm
	Mz (dynamic)	±1 000 Nm
<b>Weight and centre of gravity (Z)</b>		
P1907		6.0 kg / 62 mm
P1907 with P0409/ P0418		7.5 kg / 74 mm
P1907 with P0404/ P0474		8.2 kg / 80 mm
<b>Rotational torque</b>		45 Nm
<b>Air channels</b>	Pneumatic diagram	See section 2.1.14
	User channels, robot side Dedicated channels, G 1/8"	6 x G 1/8" (800 l/min, max 10 bar) Open TC marked 8/OPEN. Close TC marked 7/CLOSE (6-10 bar)
	Air quality	Oil-clean and waterless filtered air, with max 25µm particle content
<b>Electrical signals</b>	Circuit diagram	E0199-002 (see section 2.1.16)
	Total signals	12 x (1A, 60V)
	Dedicated signals	24V, 0V, TC Coupled, TC Uncoupled
	Connection, robot side	Souriau 12P (UT001412PHT)
<b>Connection kits (optional)</b>	P8006 (connector)	Souriau 12S (straight)
	P8006-2 (connector)	Souriau 12S (angled)
	P8116-40 (cable kit)	Souriau 12S, 4-meter cable, open end

## 2.1.7 Swivel tool changer STC100-6E sealed. Article no: P1915

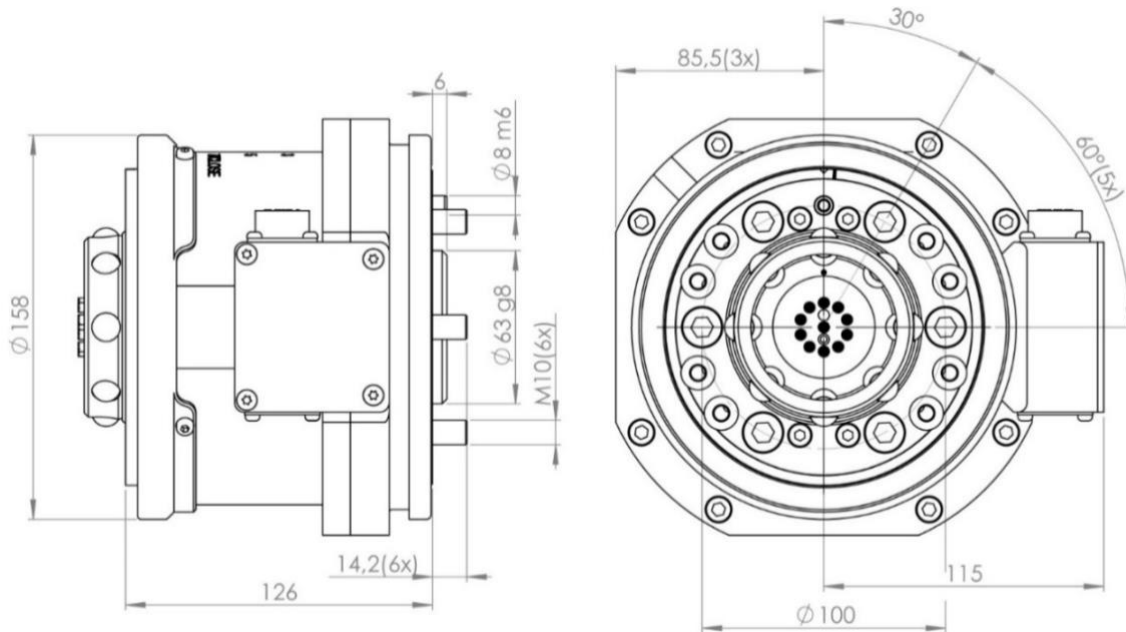

Swivel tool changer STC100-6E transfers 6 pneumatic channels and 12 electrical signals to the tool attachment and has separate inlets for Open TC and Close TC. To be used together with P0409, P0404, P0418 or P0474.

### Technical data

<b>Working temperature</b>		+10°C–+50°C
<b>Bolt pattern</b>		ISO 9409-1 100-6-M10
<b>IP classification</b>		IP 65
<b>Maximum tool load</b>	Fz (static) Mx/My (dynamic) Mz (dynamic)	±1 000 N ±1 000 Nm ±1 000 Nm
<b>Weight and centre of gravity (Z)</b>		
P1915		6.7 kg / 71 mm
P1915 with P0409/P0418		8.2 kg / 84 mm
P1915 with P0404/P0474		8.9 kg / 89 mm
<b>Rotational torque</b>		45 Nm
<b>Air channels</b>	Pneumatic diagram User channels, robot side Dedicated channels, G 1/8"  Air quality	See section 2.1.14 6 x G 1/8" (800 l/min, max 10 bar) Open TC marked 8/OPEN. Close TC marked 7/CLOSE (6-10 bar) Oil-clean and waterless filtered air, with max 25µm particle content
<b>Electrical signals</b>	Circuit diagram Total signals Dedicated signals Connection, robot side	E0199-002 (see section 2.1.16) 12 x (1A, 60V) 24V, 0V, TC Coupled, TC Uncoupled Souriau 12P (UT001412PHT)
<b>Connection kits (optional)</b>	P8006 (connector) P8006-2 (connector) P8116-40 (cable kit)	Souriau 12S (straight) Souriau 12S (angled) Souriau 12S, 4-meter cable, open end

## 2.1.8 Swivel tool changer STC100-2E. Article no: P1909

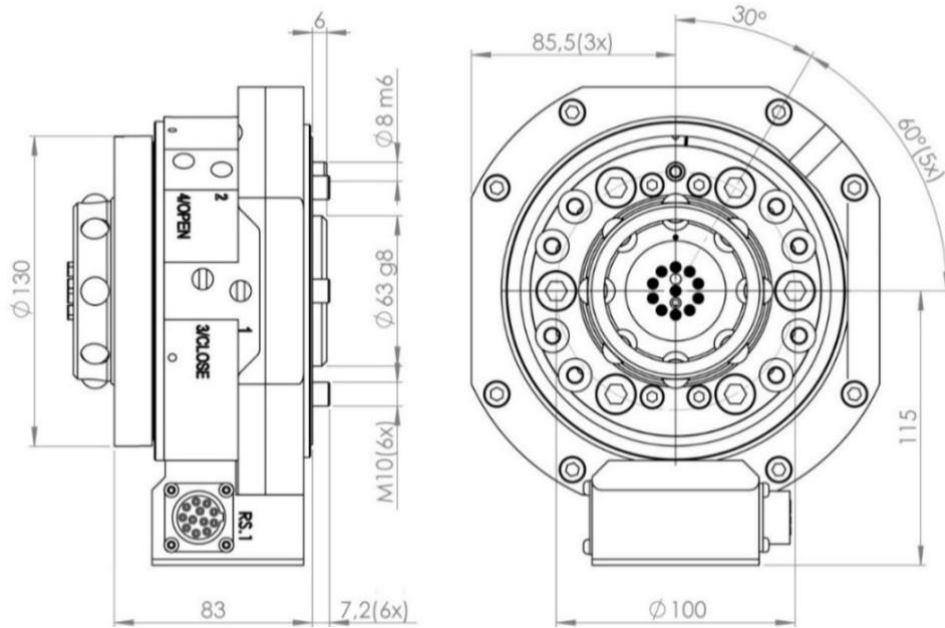

Swivel tool changer STC100-2E transfers 2 pneumatic channels and 12 electrical signals to the tool attachment and has separate inlets for Open TC and Close TC. To be used together with P0409, P0404, P0418 or P0474.

### Technical data

<b>Working temperature</b>		+10°C–+50°C
<b>Bolt pattern</b>		ISO 9409-1 100-6-M10
<b>IP classification</b>		IP 54
<b>Maximum tool load</b>	Fz (static)	±1 000 N
	Mx/My (dynamic)	±1 000 Nm
	Mz (dynamic)	±1 000 Nm
<b>Weight and centre of gravity (Z)</b>		
P1909		5.2 kg / 48 mm
P1909 with P0409/ P0418		6.7 kg / 60 mm
P1909 with P0404/ P0474		7.4 kg / 65 mm
<b>Rotational torque</b>		35 Nm
<b>Air channels</b>	Pneumatic diagram	See section 2.1.15
	User channels, robot side Dedicated channels, G 1/8"	2 x G 1/8" (800 l/min, max 10 bar) Open TC marked 4/OPEN. Close TC marked 3/CLOSE (6-10 bar)
	Air quality	Oil-clean and waterless filtered air, with max 25µm particle content
<b>Electrical signals</b>	Circuit diagram	E0199-002 (see section 2.1.16)
	Total signals	12 x (1A, 60V)
	Dedicated signals	24V, 0V, TC Coupled, TC Uncoupled
	Connection, robot side	Souriau 12P (UT001412PHT)
<b>Connection kits (optional)</b>	P8006 (connector)	Souriau 12S (straight)
	P8006-2 (connector)	Souriau 12S (angled)
	P8116-40 (cable kit)	Souriau 12S, 4-meter cable, open end

## 2.1.9 Swivel tool changer STC100-2E sealed. Article no: P1916

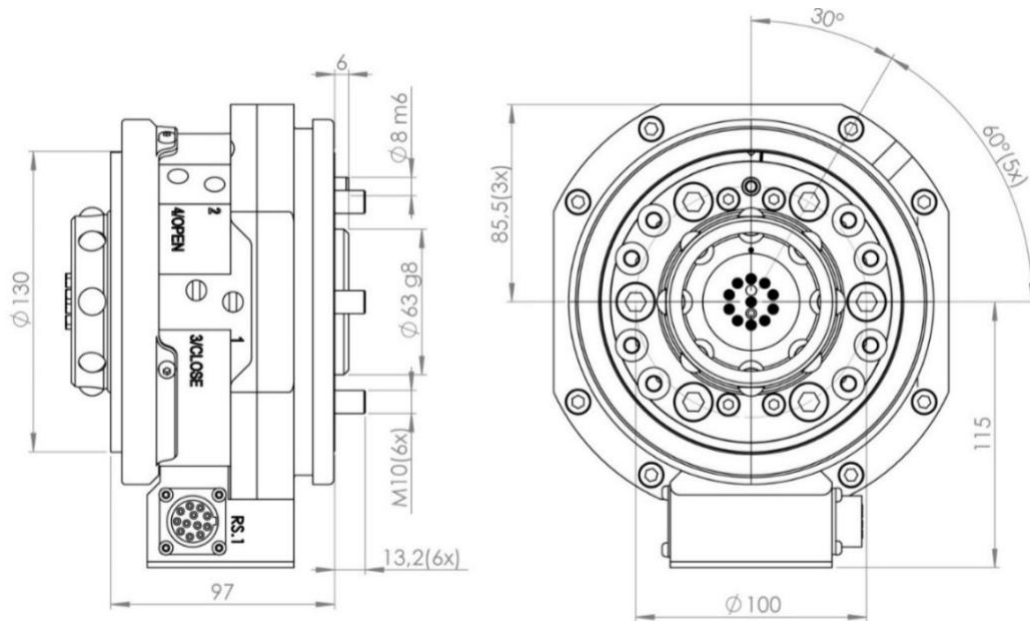

Swivel tool changer STC100-2E transfers 2 pneumatic channels and 12 electrical signals to the tool attachment and has separate inlets for Open TC and Close TC. To be used together with P0409, P0404, P0418 or P0474.

### Technical data

<b>Working temperature</b>		+10°C–+50°C
<b>Bolt pattern</b>		ISO 9409-1 100-6-M10
<b>IP classification</b>		IP 65
<b>Maximum tool load</b>	Fz (static)	±1 000 N
	Mx/My (dynamic)	±1 000 Nm
	Mz (dynamic)	±1 000 Nm
<b>Weight and centre of gravity (Z)</b>		
P1916		5.8 kg / 57 mm
P1916 with P0409/ P0418		7.4 kg / 68 mm
P1916 with P0404/ P0474		8.0 kg / 73 mm
<b>Rotational torque</b>		35 Nm
<b>Air channels</b>	Pneumatic diagram	See section 2.1.15
	User channels, robot side Dedicated channels, G 1/8"	2 x G 1/8" (800 l/min, max 10 bar) Open TC marked 4/OPEN. Close TC marked 3/CLOSE (6-10 bar)
	Air quality	Oil-clean and waterless filtered air, with max 25µm particle content
<b>Electrical signals</b>	Circuit diagram	E0199-002 (see section 2.1.16)
	Total signals	12 x (1A, 60V)
	Dedicated signals	24V, 0V, TC Coupled, TC Uncoupled
	Connection, robot side	Souriau 12P (UT001412PHT)
<b>Connection kits (optional)</b>	P8006 (connector)	Souriau 12S (straight)
	P8006-2 (connector)	Souriau 12S (angled)
	P8116-40 (cable kit)	Souriau 12S, 4-meter cable, open end



## 2.1.10 Tool attachment, TA100-8E. Article no: P0409

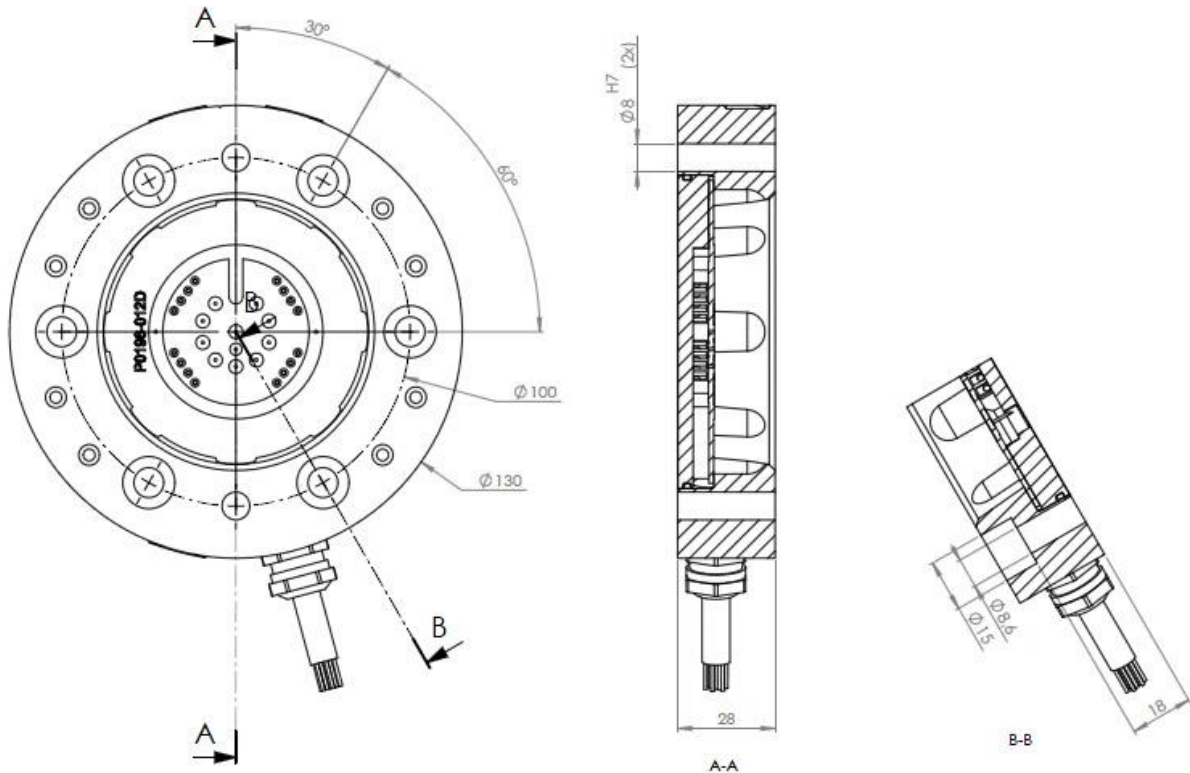

Tool attachment TA 100-8E transfers 8 pneumatic channels and 10 electrical signals to the tool. To be used together with P1907, P1915, P1909 or P1916.

### Technical data

<b>Working temperature</b>		+10°C–+50°C
<b>Bolt pattern</b>		ISO9409-1-100-6-M8
<b>Weight</b>		1.5 kg
<b>Maximum tool load</b> (screw class 8.8)	Fz (static) Mx/My (dynamic) Mz (dynamic)	±1 000 N ±1 000 Nm ±600 Nm
<b>Maximum tool load</b> (screw class 12.9)	Fz (static) Mx/My (dynamic) Mz (dynamic)	±1 000 N ±1 000 Nm ±1 000 Nm
<b>Air channels</b>	Connection, tool side	8 x G 1/8"
<b>Electrical signals</b>	Total number of signals Dedicated signals Connection, tool side	10 24 V, 0V 1.0 m cable (10x0.5mm <sup>2</sup> ) with free end



### NOTE!

The tool attachment shall be mounted to the tool using six M8-screws.

## 2.1.11 Tool attachment, TA100-8E. Article no: P0418

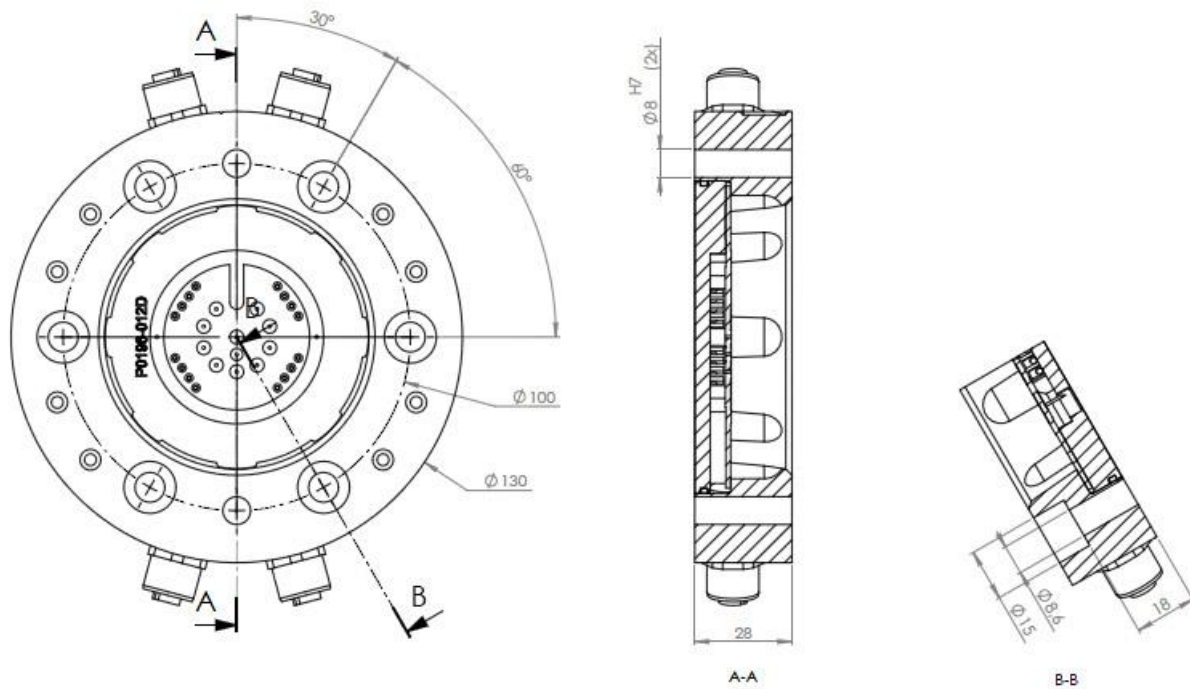

Tool attachment TA 100-8E transfers 8 pneumatic channels and 16 electrical signals to the tool. To be used together with P1907, P1915, P1909 or P1916.

### Technical data

<b>Working temperature</b>		+10°C–+50°C
<b>Bolt pattern</b>		ISO9409-1-100-6-M8
<b>Weight</b>		1.5 kg
<b>Maximum tool load</b> (screw class 8.8)	Fz (static) Mx/My (dynamic) Mz (dynamic)	±1 000 N ±1 000 Nm ±600 Nm
<b>Maximum tool load</b> (screw class 12.9)	Fz (static) Mx/My (dynamic) Mz (dynamic)	±1 000 N ±1 000 Nm ±1 000 Nm
<b>Air channels</b>	Connection, tool side	8 x G 1/8"
<b>Electrical signals</b>	Total number of signals Dedicated signals Connection, tool side	16 4 x 24V, 4 x 0V 4 x M12 4S
<b>Connection kits</b> (optional)	4 x I0615 (cable kit)	M12 4P, 5-meter cable, open end



### NOTE!

The tool attachment shall be mounted to the tool using six M8-screws.

## 2.1.12 Square tool attachment, TA100-8E. Article no: P0404

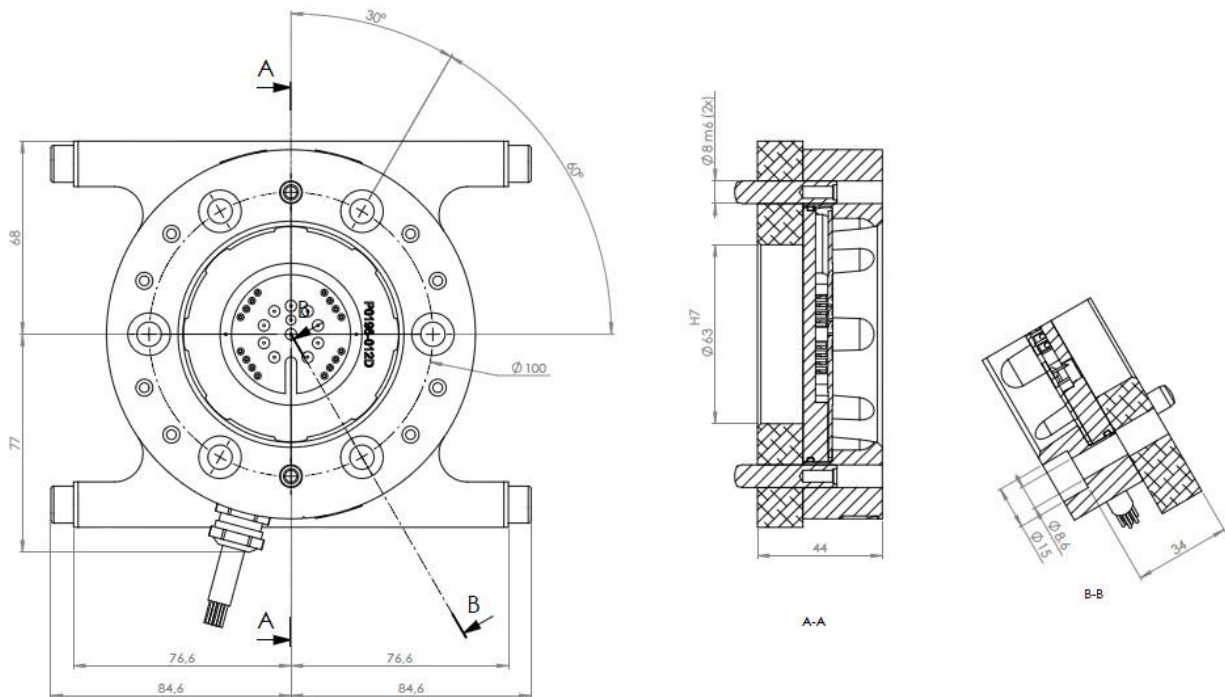

Tool attachment TA 100-8E transfers 8 pneumatic channels and 10 electrical signals to the tool and gives together with option P0423 a stable tool stand for easy tool changing. To be used together with P1907, P1915, P1909 or P1916.

### Technical data

<b>Working temperature</b>		+10°C–+50°C
<b>Bolt pattern</b>		ISO9409-1-100-6-M8
<b>Weight</b>		2.2 kg
<b>Maximum tool load</b> (screw class 8.8)	Fz (static) Mx/My (dynamic) Mz (dynamic)	±1 000 N ±1 000 Nm ±600 Nm
<b>Maximum tool load</b> (screw class 12.9)	Fz (static) Mx/My (dynamic) Mz (dynamic)	±1 000 N ±1 000 Nm ±1 000 Nm
<b>Air channels</b>	Connection, tool side	8 x G 1/8"
<b>Electrical signals</b>	Total number of signals Dedicated signals Connection, tool side	10 24V, 0V 1.0 m cable (10x0.5mm <sup>2</sup> ) with free end



### NOTE!

The tool attachment shall be mounted to the tool using six M8-screws.

## 2.1.13 Square tool attachment, TA100-8E. Article no: P0474

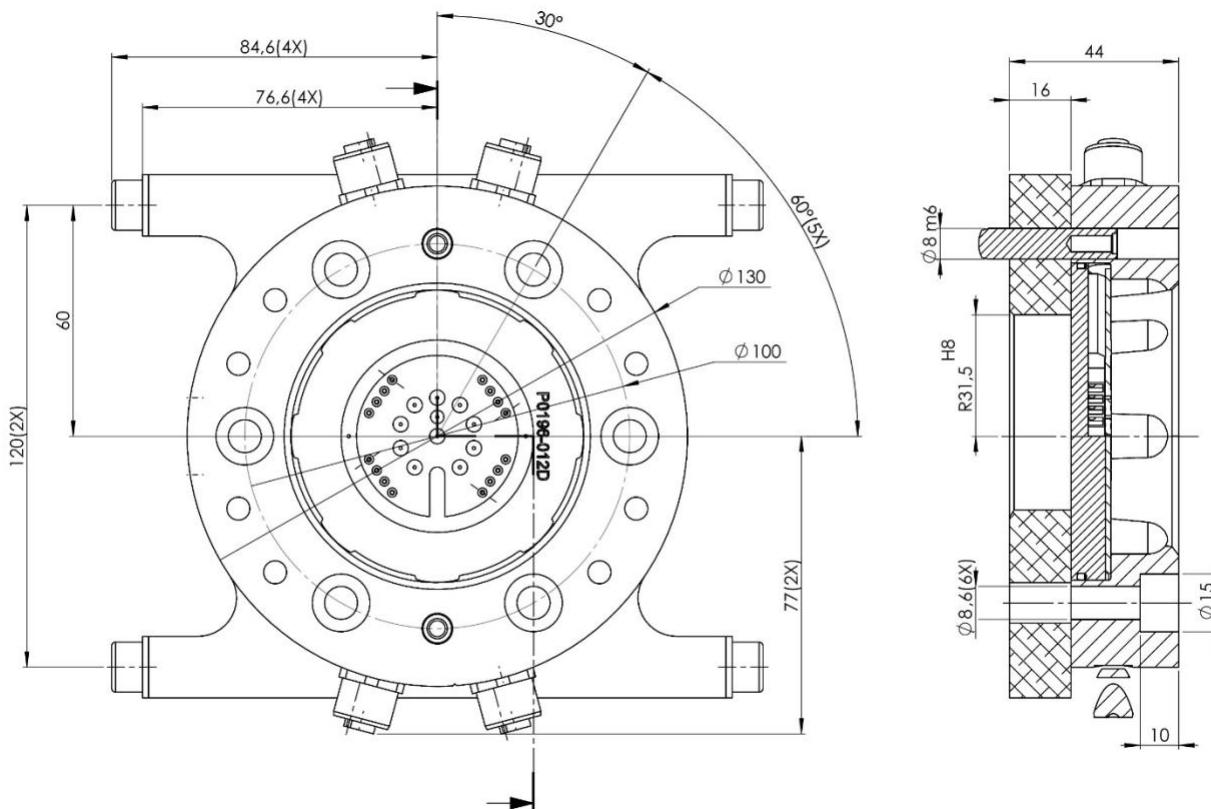

Tool attachment TA 100-8E transfers 8 pneumatic channels and 16 electrical signals to the tool and gives together with option P0423 a stable tool stand for easy tool changing. To be used together with P1907, P1915, P1909 or P1916.

### Technical data

<b>Working temperature</b>		+10°C–+50°C
<b>Bolt pattern</b>		ISO9409-1-100-6-M8
<b>Weight</b>		2.2 kg
<b>Maximum tool load</b> (screw class 8.8)	Fz (static)	±1 000 N
	Mx/My (dynamic)	±1 000 Nm
	Mz (dynamic)	±600 Nm
<b>Maximum tool load</b> (screw class 12.9)	Fz (static)	±1 000 N
	Mx/My (dynamic)	±1 000 Nm
	Mz (dynamic)	±1 000 Nm
<b>Air channels</b>	Connection, tool side	8 x G 1/8"
<b>Electrical signals</b>	Total number of signals	16
	Dedicated signals	4 x 24V, 4 x 0V
	Connection, tool side	4 x M12 4S
<b>Connection kits (optional)</b>	4 x I0615 (cable kit)	M12 4P, 5-meter cable, open end



### NOTE!

The tool attachment shall be mounted to the tool using six M8-screws.

### 2.1.14 Pneumatic diagram STC100-6 and STC100-6E

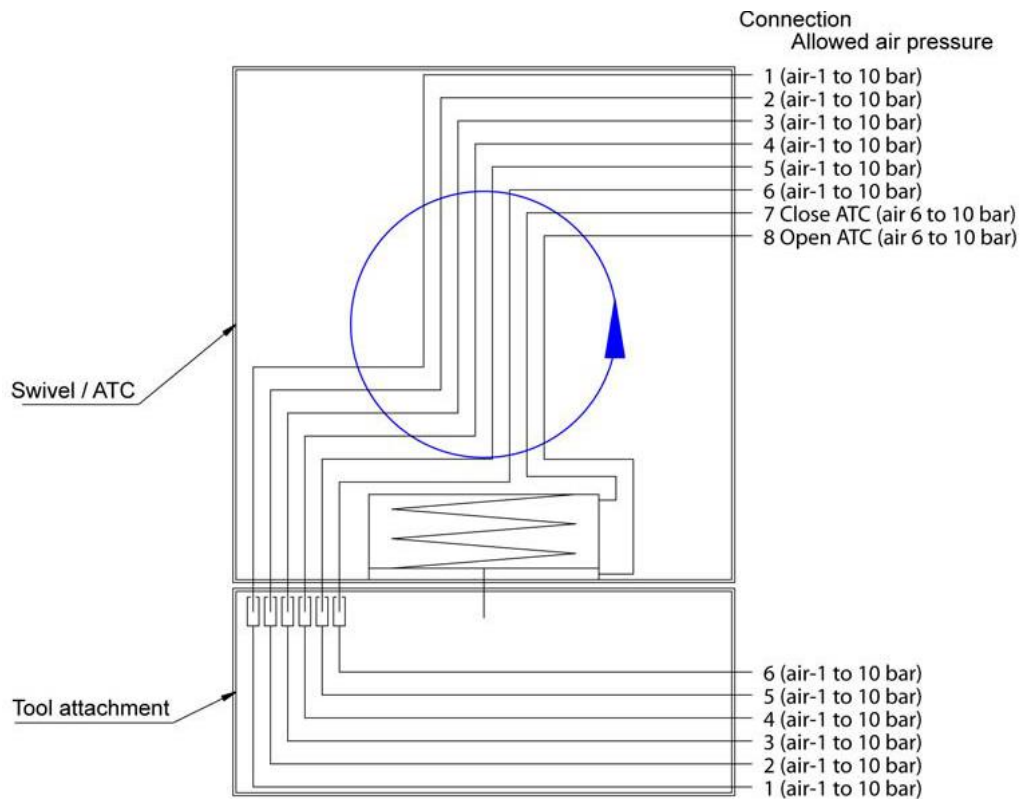

### 2.1.15 Pneumatic diagram STC100-2 and STC100-2E

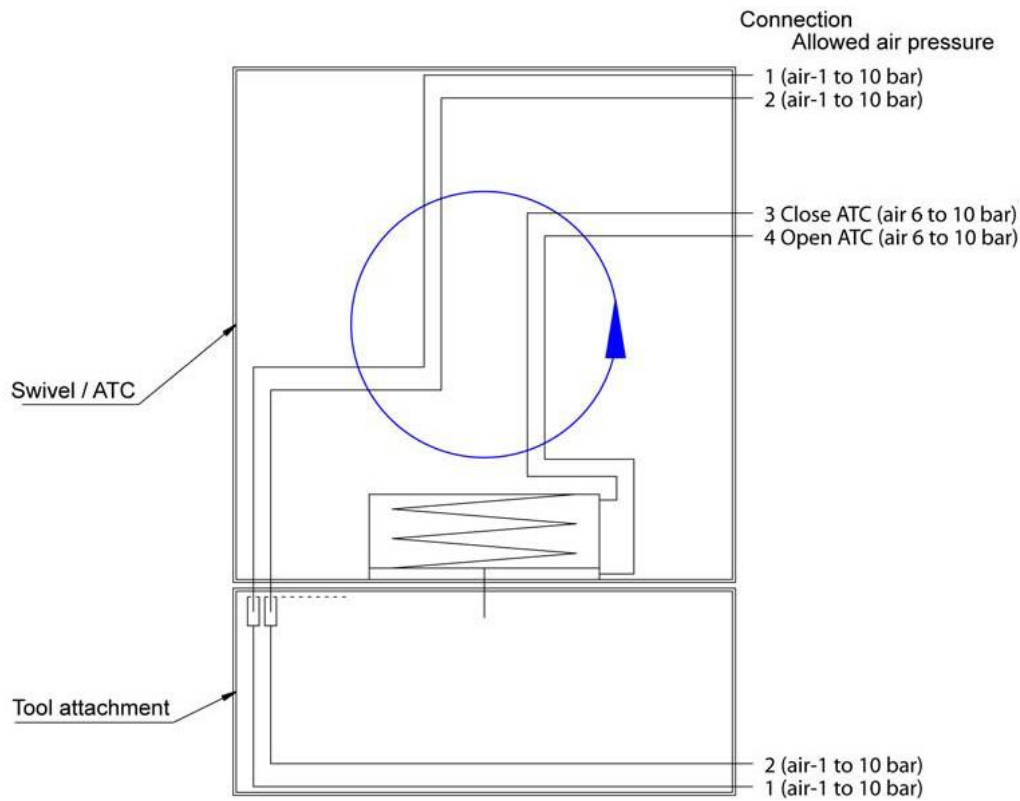





## 2.2 Options for swivel tool changer

### 2.2.1 Robot adaptation kit

A robot adaptation kit is mandatory for mounting of a swivel tool changer to a robot. The adaptation kits always include rotation stops which are prohibiting the swivel tool changers to rotate in relation to the robots. Dependent on robot model an adaptation kit may also include an adaptation plate for other bolt circles. Robot adaptation kits are available from RSP.

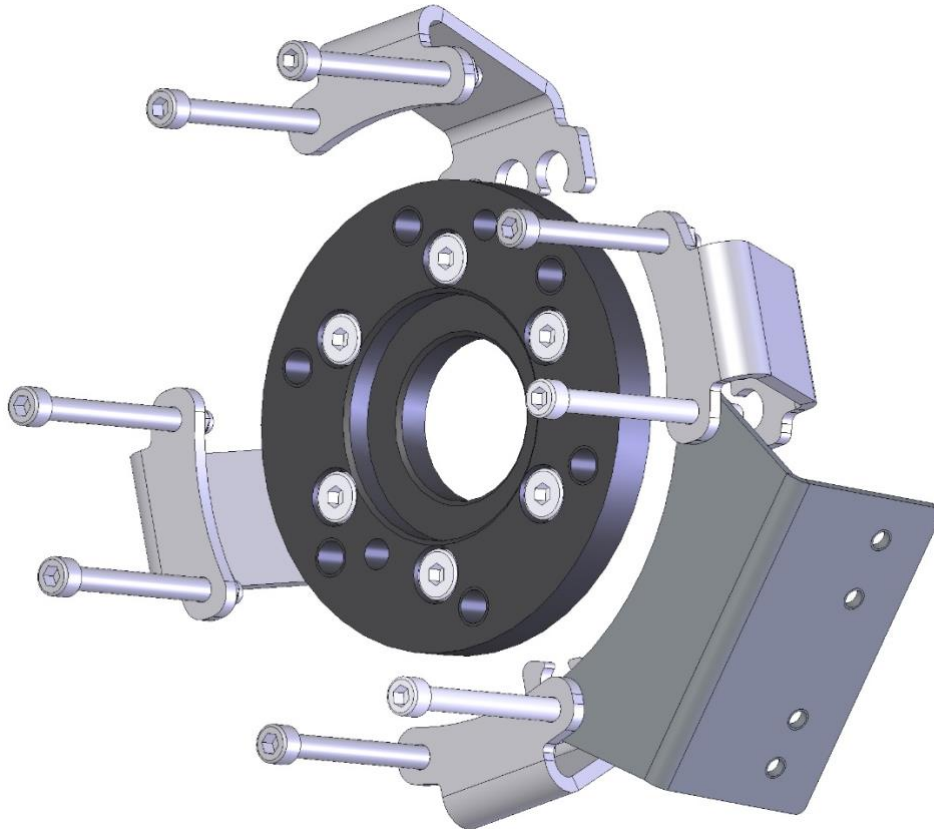

*Example of adaptation kit including rotation stop, adaptation plate and hose holder*



**NOTE!** Dependent on robot model and rotation stop, there can be limitations on the freedom of movement of axis 5. Contact Robot System Products for more information.

### 2.2.2 Tool Identification

Jumpers on signals at the tool attachment can be used to give information about which tool attachment that is docked in the swivel tool changer.

### 2.2.3 Tool stand kit. Article no: P0423

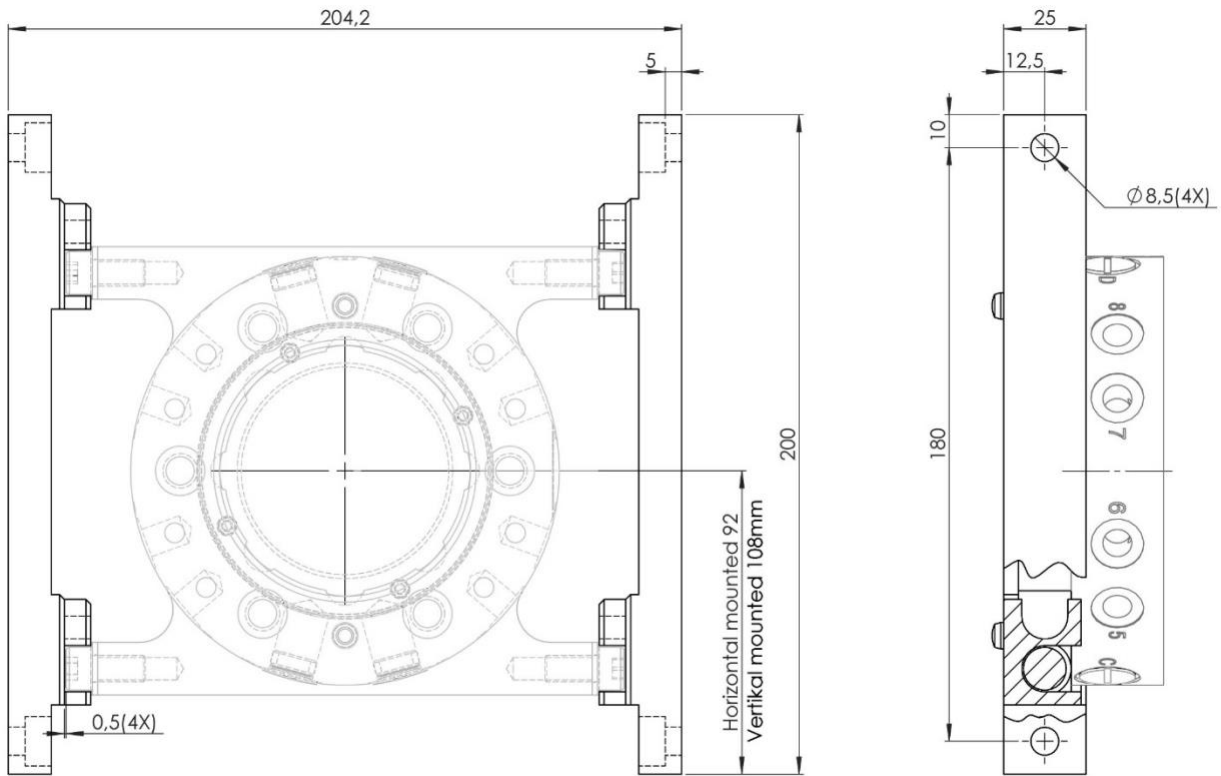

This tool stand kit, mounted on a stand, gives in combination with square tool attachments P0402 or P0404 a robust tool stand for easy tool changing.

#### Technical data

<b>Weight</b>	0.7 kg
<b>Maximum load</b>	180 kg

### 2.2.4 Limitation of Robot movements

There can be some limitations on the movement of axis 5 for some robot models. Contact Robot System Products for more information.



### 3 SPARE PARTS

#### 3.1 Part list for swivel tool changer P1908, P1907 and P1915

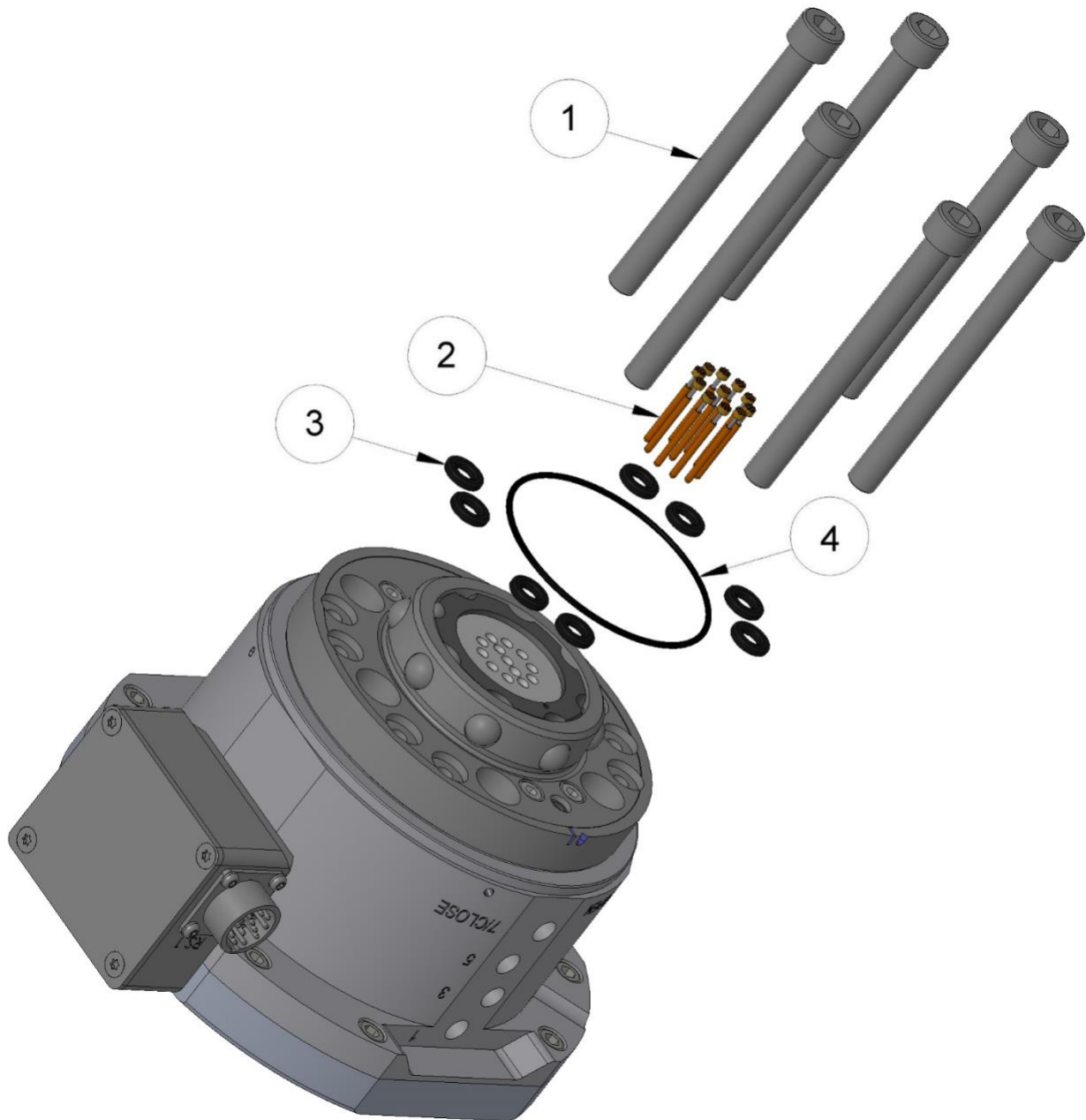

Item	Description	Part number	Wear part	Pcs
1	Fastening screw M10x110 (P1908 and P1907)	MC6S 10x110		6
1	Fastening screw M10x130 (P1915)	MC6S 10x130		6
2	Spring loaded signal pin (STC100-6E only)	I0042	X	11
3	Air sealing	I0230	X	8
4	O-ring	I1459	X	1

### 3.2 Part list for swivel tool changer P1910, P1909 and P1916

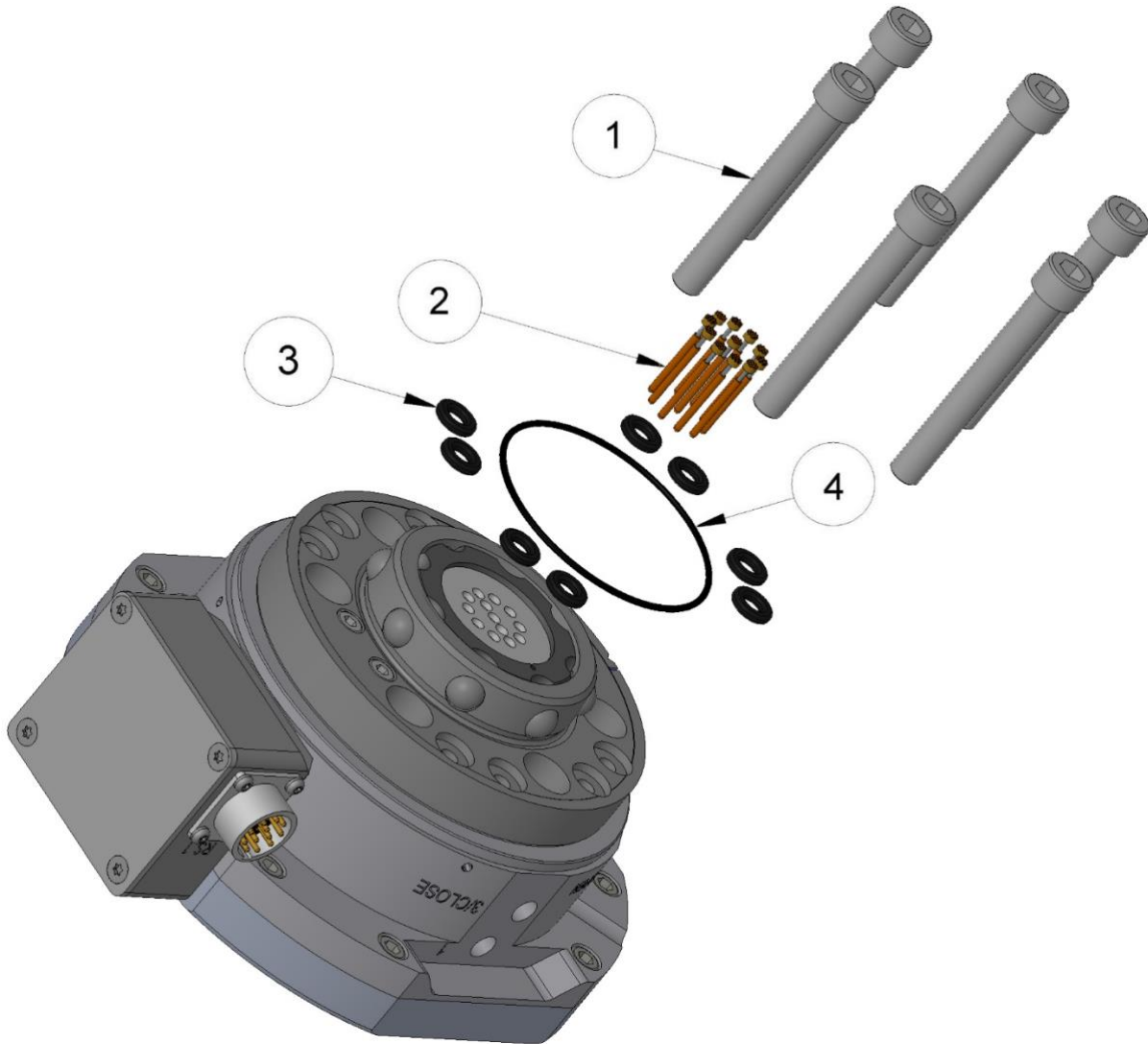

Item	Description	Part number	Wear part	Pcs
1	Fastening screw M10x80 (P1910 and P1909)	21212519-507		6
1	Fastening screw M10x100 (P1916)	MC6S 10x100		6
2	Spring loaded signal pin (STC100-2E only)	I0042	X	11
3	Air sealing	I0230	X	8
4	O-ring	I1459	X	1



