

# Installation and Maintenance

## Swivel tool changers STC20–STC350

M0412-1

Tool changers | Swivels | Swivels Tool changers | Grippers | Hose packages | Valve Units | Tool systems





The information in this document is subject to change without prior notice and should not be regarded as an undertaking from Robot System Products AB. Robot System Products AB assumes no responsibility for errors that may occur in this document.

Robot System Products AB bears no responsibility for damage that is incurred by the use of this document, or the software or hardware described in this document.

The document, or parts of it, may not be reproduced or copied without prior permission from Robot System Products AB. It may neither be imparted to a third party, nor otherwise be used without authorization. Infringement hereof will be subject to action in accordance with the applicable laws.

Further copies of this document can be obtained from Robot System Products AB at current prices.

© Robot System Products AB

Robot Systems Products AB  
Isolatorvägen 4  
SE-721 37 Västerås  
Sweden

# CONTENTS

<b>1 INTRODUCTION .....</b>	<b>5</b>
1.1 Installation and Maintenance manual .....	5
1.2 Safety .....	6
1.2.1 General.....	6
1.2.2 Explanation of warnings .....	6
1.3 Tightening torques.....	7
1.4 Recommended equipment .....	7
1.5 Required products .....	7
<b>2 INSTALLATION .....</b>	<b>8</b>
2.1 Installation of swivel tool changer on robot .....	8
2.2 Installation of tool attachment on tool .....	11
2.3 Manual unlocking of swivel tool changer .....	13
<b>3 MAINTENANCE AND SERVICE.....</b>	<b>14</b>
3.1 Maintenance scheme .....	14
3.1.1 Every second week .....	14
3.1.2 Every six-months or 250,000 tool changes .....	14
3.1.3 To replace when damaged or worn-out .....	15
3.1.4 Complete service of swivel tool changer.....	15
3.2 Specification of maintenance activities .....	16
3.2.1 Visual inspection of swivel tool changer.....	16
3.2.2 Visual inspection and cleaning of tool attachment .....	17
3.2.3 Cleaning and lubrication of swivel tool changer .....	18
3.2.4 Cleaning and lubrication of tool attachment .....	19
<b>4 DISMOUNTING AND REPLACEMENT .....</b>	<b>20</b>
4.1 Replacement of swivel tool changer .....	20
4.2 Replacement of tool attachment .....	22
4.3 Replacement of wear parts.....	23
4.3.1 Replacement of air sealings .....	23
4.3.2 Replacement of signal pins (electrical versions only) .....	24
4.3.3 Replacement of O-ring (STC100, STC250 and STC350 only) .....	25
<b>5 DISPOSAL AND RECYCLING .....</b>	<b>26</b>

# 1 INTRODUCTION

**Robot System Products** is a front-rank provider of peripheral products for high performance robot applications. We provide complete tool systems solutions for your robot installations, aiming to improve your productivity with the most reliable and cost-effective tooling on the market. Continuously we explore emerging technologies, working with leading edge design.

**Robot System Products** has a wide range of standard robot peripheral products:



- Tool changers
- Swivels
- Swivel tool changers
- CiRo
- Grippers
- Hose Packages
- Valve units
- Tool systems
- Tool parking systems

**Robot System Products'** tool changers are constructed to maximize the flexibility and reliability of your robot fleet. Through our patented locking device TrueConnect™ robustness and high safety are combined with low weight and compactness. With our swivels compressed air, water, electrical and data signals as well as weld and servo power are transferred to your tools with robot motion capabilities fully maintained. Our Swivel tool changers unite the TrueConnect™ mechanism with our swivel technology, combining the best out of the two technologies. With RSPs unique Circular Rotators cables and hoses can be freely selected with high robot flexibility maintained, and the space requirements reduced. Our integrated Tool systems are delivered as complete plug-and-play solutions designed for quick and simple installation.

**Robot System Products'** product lines are available for all major robot brands and come with complete documentation. 3D-models for simulation are available for download at:

[www.rsp.eu.com](http://www.rsp.eu.com)

## ***1.1 Installation and Maintenance manual***

This document describes how the swivel tool changers, STC20, STC100, STC250 and STC350, including corresponding tool attachments and options for transfer of power, signals and air are installed and replaced. In addition, the document describes required maintenance activities, including inspection, cleaning, lubrication, replacement of wear parts, required tools and products and disposal and recycling.

The *Product Descriptions* of each respective unit are separate documents containing product information, drawings, technical data, electrical and pneumatic diagrams and lists of spare parts.

## 1.2 Safety

### 1.2.1 General

The integrator installing the swivel tool changer into the system must follow the safety demands stated in standards and provisions applicable in the country where the swivel tool changer system is to be installed. The products are all prepared for CE-certification.

The user of the Robot System Products swivel tool changer is responsible that law and directives applicable in respective countries, with regards to safety, are followed. The user is also responsible to guarantee that all safety devices are installed correctly.



**WARNING!**

Never carry out service work on a robot that has not been taken out of operation. See safety information for the robot.



**WARNING!**

Only perform work on tools attached to the swivel tool changer if the air pressure is safely switched off.



**WARNING!**

Be aware that swivel tool changers and tool attachments are heavy and may cause personal injury and equipment damage if dropped.



**NOTE!**

The swivel tool changer shall always be in locked position, also when empty, to avoid unexpected locking if air pressure is lost.



**WARNING!**

Electric signals and power must be disconnected/switched off when docking the tool attachment. This is to prevent sparking between signal pins and tool attachment.

### 1.2.2 Explanation of warnings

The warnings in this document are specific to the products in this manual. It is expected that the user also pay attention to certain notifications from the robot manufacturer and/or the manufacturers of other components used in the installation.



**WARNING!**

The warning sign will make you aware that a situation could result in potential serious injury or damage to equipment.



**NOTE!**

The note sign will alert you about something important to consider.

## 1.3 Tightening torques

### Tightening torques for mounting (screw class 8.8)

Dimension	Torque
M8	24 Nm
M10	47 Nm
M12	82 Nm
M14	131 Nm
M16	200 Nm

### Tightening torques for mounting (screw class 12.9)

Dimension	Torque
M8	41 Nm
M10	79 Nm
M12	138 Nm
M14	221 Nm
M16	338 Nm

## 1.4 Recommended equipment

### Equipment recommended for installation and maintenance work

Tools	Applications
Complete set of Allen keys	For all socket head cap screws
Torque wrench	For dismounting and mounting
Pair of pliers	For dismounting the signal pins
Screw driver	For removing the air sealings

## 1.5 Required products



Product	Specification	Note
Grease, 3HXG1000-413	Magnalube-G, Teflon grease	Air sealings and O-rings.
Grease I0876	Molykote BR2Plus	For locking balls.
Cleaning agent	Industrial alcohol or similar	For cleaning of tool changer and tool attachment.
Glue	Loctite 480 (or similar)	For gluing the air sealings.
Cloth	Lint free cloth	For cleaning.



**NOTE!** Chemical resistance protective gloves are recommended when using grease or cleaning agents such as industrial alcohol. Safety goggles are recommended when working with cleaning agents such as industrial alcohol. Adequate ventilation should be provided when chemical substances are used.

## 2 INSTALLATION

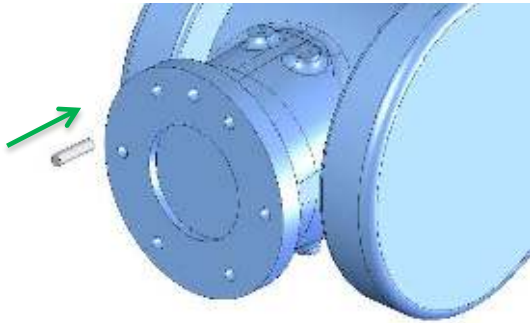
### 2.1 Installation of swivel tool changer on robot

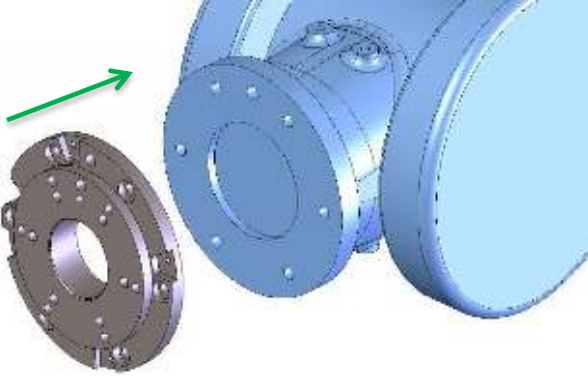
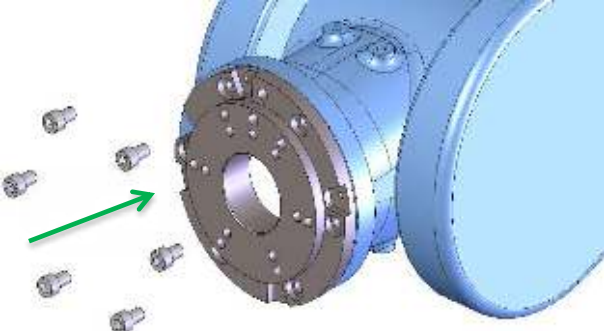
	Action	Note
	<b>Safety</b>	Read the <a href="#">safety section 1.2</a> .
	<b>Service position</b>	Place the robot in service position.
	<b>Power off</b>	Switch the power off and lock the circuit breaker. <b>NOTE!</b> Read the safety chapter for the robot.
	<b>Mount guide pin</b> 	Press the enclosed guide pin into the robot flange.
	<b>Fit adaptation plate</b> 	Lift the adaptation plate and fit the guide pin to the guide hole in robot flange.  <b>NOTE!</b> Only if adaptation plate is used.
	<b>Mount adaptation plate</b> 	Mount the adaptation plate with the enclosed screws. Use a torque wrench when tightening (see tightening torques above).





7

### Fit the swivel tool changer to robot

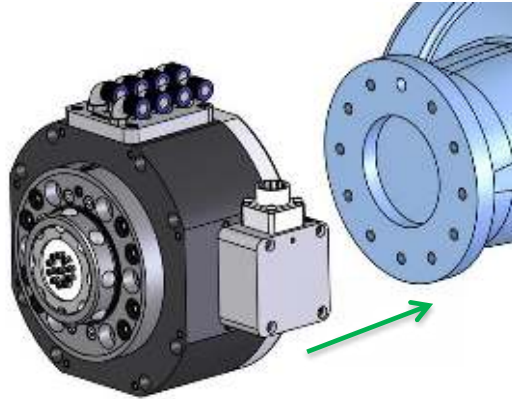

Lift the swivel tool changer to the robot flange (or adaptation plate). Make sure that the guide pin fits to the guide hole in the swivel tool changer.

**WARNING!** The swivel tool changer is heavy and may cause damage if dropped.

8

### Mount swivel tool changer

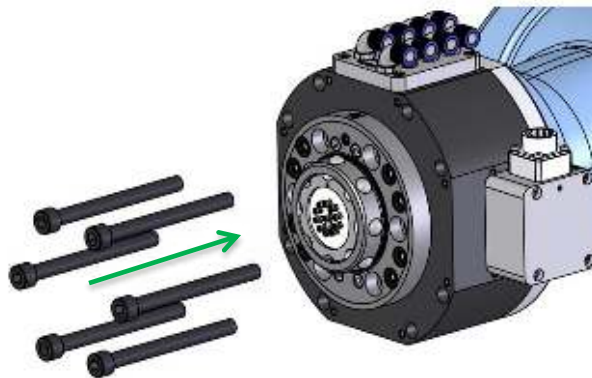

Mount the swivel tool changer with the enclosed screws. Use a torque wrench when tightening (see tightening torques above).

**NOTE!** Some rotation stops should be mounted on the STC before it is mounted on the robot.



9

### Turn robot arm into position

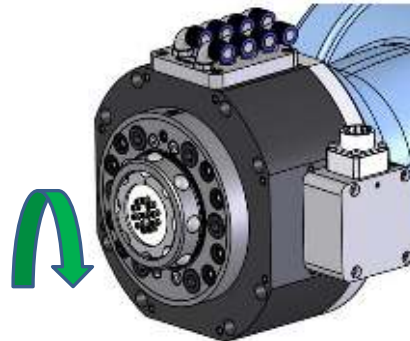

Rotate axis 6 to put the rotation stop in position for mounting.

10A

### Mount rotation stops (STC20 and STC100)

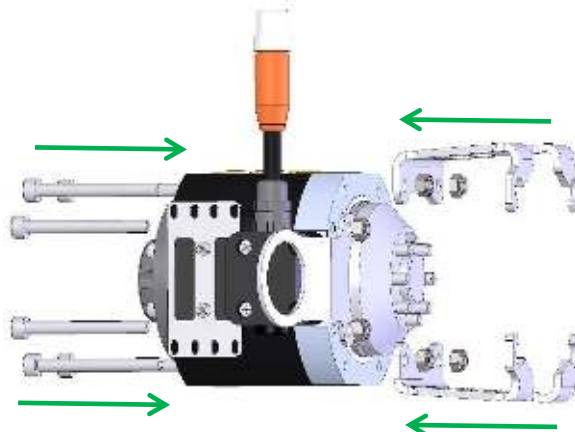

Mount the rotation stops with enclosed screws and nuts. The tightening torque for STC20 is 4 Nm, and for STC100 it is 6 Nm.

**NOTE!** Design and mounting methods are dependent on STC and robot models.

**NOTE!** Mounting instructions are included in the adaptation kits.



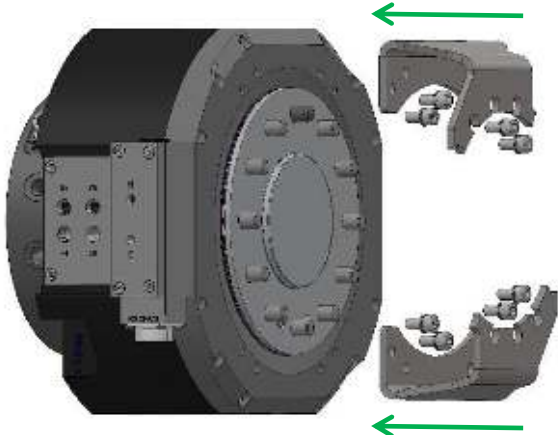
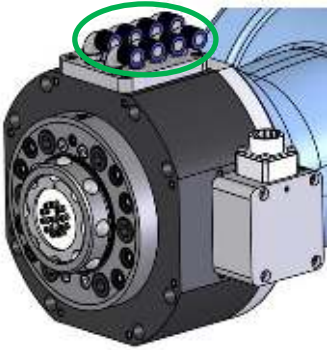
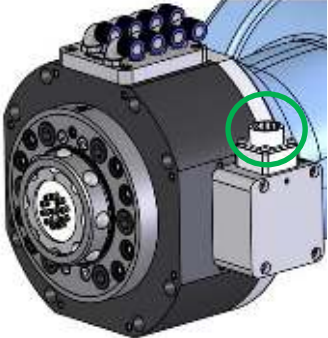

10B	<b>Mount rotation stops (STC250 and STC350)</b> 	Mount the rotation stops with enclosed screws and nuts. The tightening torque for STC250 and STC350 is 10 Nm.  <b>NOTE!</b> Design and mounting methods are dependent on STC and robot models.  <b>NOTE!</b> Mounting instructions are included in the adaptation kits.
11	<b>Connect air</b> 	Mount air hoses using hose fittings.  Pneumatic diagrams are found in the <i>Product Description</i> of respective unit.
12	<b>Connect signals (electrical versions only)</b> 	Connect electrical connectors in accordance with selected unit.  Circuit diagrams are found in the <i>Product Description</i> of respective unit.
13	<b>Power on</b>	Unlock the circuit breaker and switch the power on.

## 2.2 Installation of tool attachment on tool

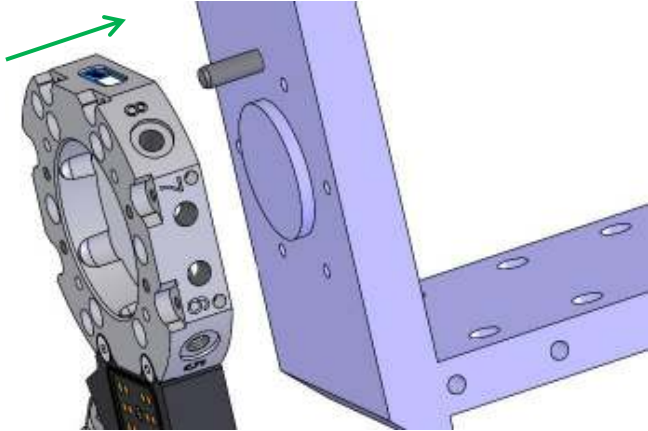
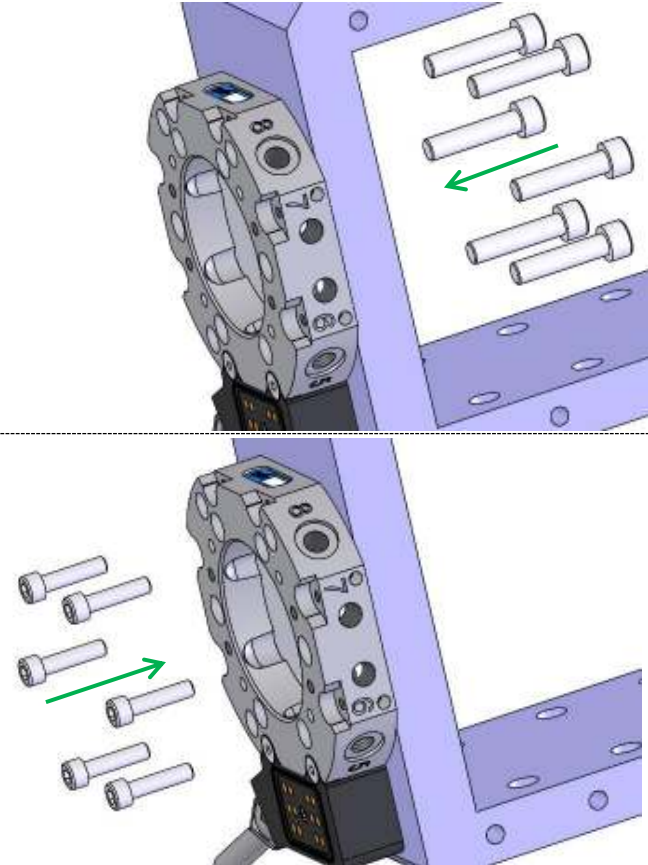

	Action	Note
1	<b>Safety</b>	Read the <a href="#">safety section 1.2</a> .
2	<b>Mount guide pins</b>	Press guide pins, as applicable, into the corresponding holes on the tool.
3	<b>Fit tool attachment</b> 	Fit the tool attachment and tool to each other using the guide pins.  <b>WARNING!</b> The tool attachment is heavy and may cause personal injury and equipment damage if dropped.
4	<b>Mount tool attachment</b> 	Fastening screws can be entered either from the tool attachment side or the tool side. Screws are specified in the Product Description of respective tool attachment. Mount the tool attachment using a torque wrench. See tightening torques above.  <b>NOTE!</b> For TA100 fastening screws can only be entered from the tool attachment side.

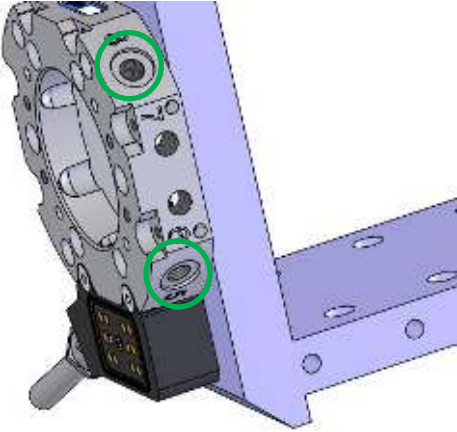
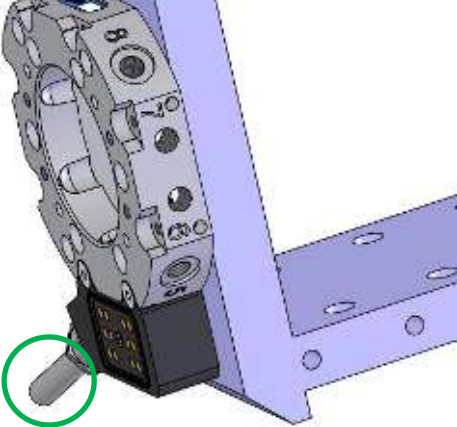

5	<b>Connect air hoses</b> 	Connect air hoses to the tool attachment.  Pneumatic diagrams are found in the Product Description of respective unit.
6	<b>Connect signals (electrical versions only)</b> 	Connect electrical connectors in accordance with selected unit.  Circuit diagrams are found in the Product Description of respective unit.

## 2.3 Manual unlocking of swivel tool changer



	Action	Note
1	<b>Safety</b>	Read the <a href="#">safety section 1.2</a> .
2	<b>Park the tool</b>	Park the tool on a tool stand or table.  <b>NOTE!</b> Make sure that the tool attachment and tool are fully supported by a tool stand or table.
3	<b>Service position</b>	Place the robot in service position.
4	<b>Pneumatic air off</b>	<b>NOTE!</b> The pressure in the pneumatic system must be released before dismounting begins.
5	<b>Power off</b>	Switch power off and lock the circuit breaker.  <b>NOTE!</b> Read the safety chapter for the robot.
6	<b>Release air</b>  	Release air at connections marked OPEN and CLOSE.  Pneumatic diagrams are found in the <i>Product Description</i> of respective unit.  <b>NOTE!</b> The open and close connections may have alternative markings.
7	<b>Release tool attachment</b>  	Connect compressed air to the air connection marked OPEN. Exhaust air is evacuated via connection marked CLOSE.

## 3 MAINTENANCE AND SERVICE

The swivel tool changers and the tool attachments must be maintained regularly to ensure proper function. The specified intervals are approximate and valid under normal conditions, corresponding to 2 tool changes per minute during 2 work shifts per working day, i.e. 42.000 tool changes per month. Under extreme conditions, such as dirty environments or extreme robot movements, the intervals should be shortened. Consider the table as a guide and update as your production experience of each system increases.



**NOTE!**

Read the [safety section 1.2](#) before any maintenance activities are carried out.



**NOTE!**

Swivel tool changers must only be dismantled and repaired by Robot System Products during the warranty period. Otherwise the warranty will not be valid.

### 3.1 Maintenance scheme

#### 3.1.1 Every second week

The following maintenance activities should be carried out every second week.

Activity	Equipment		Description
Inspection	Swivel tool changer	General	Visual inspection of swivel tool changer, rotation stop and cables ( <a href="#">section 3.2.1</a> ).
		Looking balls	Check locking balls ( <a href="#">section 3.2.1</a> ).
		Air sealings	Check air sealings ( <a href="#">section 3.2.1</a> ).
		Spring-loaded pins	Check spring-loaded signal pins ( <a href="#">section 3.2.1</a> ).
	Tool attachment	General	Visual inspection of tool attachment and cables ( <a href="#">section 3.2.2</a> ).
Cleaning	Tool attachment	Signal contacts	Clean contact surfaces ( <a href="#">section 3.2.2</a> ).

#### 3.1.2 Every six-months or 250,000 tool changes

The following maintenance activities should be carried out every six-months or 250,000 tool changes.

Activity	Equipment		Description
Cleaning and lubrication	Swivel tool changer	Looking balls	Clean locking balls and add new lubrication, ( <a href="#">section 3.2.3</a> ).
		Air sealings	Clean air sealings ( <a href="#">section 3.2.3</a> ).
		Spring-loaded pins (electrical versions only)	Clean spring-loaded signal pins ( <a href="#">section 3.2.3</a> ).
	Tool attachment	Locking cavities	Clean the cavities of the locking balls. ( <a href="#">section 3.2.4</a> ).
		Contact surfaces	Clean the contact surfaces of air sealings ( <a href="#">section 3.2.4</a> ).

### 3.1.3 To replace when damaged or worn-out

Equipment		Description
Swivel tool changer	Air sealings	See <a href="#">section 4.3.1.</a>
	Spring-loaded signal pins (electrical versions only)	See <a href="#">section 4.3.2.</a>
	O-ring around the ball holder	See <a href="#">section 4.3.3.</a>

### 3.1.4 Complete service of swivel tool changer

Under normal working conditions we recommend a complete service on swivel tool changers to be carried out every 30<sup>th</sup> months by qualified RSP personnel. This will ensure proper function and increase the lifespan of the swivel tool changers considerably. Please contact us for a quotation.



The 30 months swivel tool changers service at Robot System Products includes inspection and cleaning of the full unit, replacement of all wear parts including sealings, signal pins and the O-ring on the ball holder.

## 3.2 Specification of maintenance activities

### 3.2.1 Visual inspection of swivel tool changer

The following maintenance activities should be carried out on the STC every 2<sup>nd</sup> week.



Action	Note
<p><b>Check locking balls</b></p> 	<p>Check each ball to make sure it moves freely. For cleaning and lubrication of balls see <a href="#">section 3.2.3</a>.</p> <p><b>NOTE!</b> If balls get stuck there is a risk that the tool attachment jams.</p> <p><b>WARNING!</b> Risk of getting squeezed between piston and ball holder when the piston is taking closed position</p>
<p><b>Check air sealings</b></p> 	<p>Check that the air sealings are clean. For cleaning see <a href="#">section 3.2.3</a>.</p> <p>Check that the air sealings are not damaged. For making replacements see <a href="#">section 4.3.1</a>.</p>
<p><b>Check spring-loaded signal pins (electrical versions only)</b></p> 	<p>Check that the spring-loaded signal pins are clean. For cleaning see <a href="#">section 3.2.3</a>.</p> <p>Check that the spring-loaded signal pins are not worn-out or damaged. For making replacements see <a href="#">section 4.3.2</a>.</p>
<p><b>Check cables and hoses</b></p>	<p>Check cables and hoses for damages and squeezing, replace if damaged.</p>
<p><b>Check rotation stops</b></p>	<p>Check that the rotation stops are not worn-out or damaged, replace if damaged.</p>
<p><b>Check swivel tool changer in general</b></p>	<p>Check the swivel tool changer for damages. For replacement see <a href="#">section 4.1</a>.</p>



### 3.2.2 Visual inspection and cleaning of tool attachment

The following maintenance activities should be carried out on the TA every 2<sup>nd</sup> week.

<b>Action</b>	<b>Note</b>
<b>Clean contact surfaces (electrical versions only)</b> 	Wipe the contact surface with a lint free cloth.
<b>Check cables and hoses</b>	Check cables and hoses for damages and squeezing, replace if damaged.
<b>Check tool attachment in general</b>	Check the tool attachment for damages. For replacement see <a href="#">section 4.2</a> .

### 3.2.3 Cleaning and lubrication of swivel tool changer

The following maintenance activities should be carried out on the STC every 6<sup>th</sup> month or after 250,000 tool changes, whichever comes first.



Action	Note
<p><b>Clean locking balls</b></p> 	<p>Check the locking balls and wipe them clean with a lint free cloth.</p> <p><b>WARNING!</b> Risk of getting squeezed between piston and ball holder when the piston is taking closed position</p>



<p><b>Lubricate looking balls</b></p> 	<p>Apply a small amount of grease (Molykote BR2Plus) on the locking balls.</p> <p><b>NOTE!</b> It is important that this is done or else there is a risk that the tool attachment jams.</p>
--	---

<p><b>Clean air sealings</b></p> 	<p>Wipe air sealings clean with a lint free cloth.</p>
--	--

**Clean spring-loaded signal pins (electrical versions only)**



Clean the contact surfaces of the spring-loaded signal pins with a nylon brush.

**NOTE!**

Signal pins shall be cleaned whenever blackened.

### 3.2.4 Cleaning and lubrication of tool attachment

The following maintenance activities should be carried out on the TA every 6th month or after 250,000 tool changes, whichever comes first.

**Action**

**Clean locking cavities**



**Note**

Clean the cavities of the locking balls with a lint free cloth.

**NOTE!**

It is important that this is done or else there is a risk that the tool attachment jams.







**Clean contact surfaces of air sealings**



Wipe the contact surfaces of the air sealings clean with a lint free cloth.



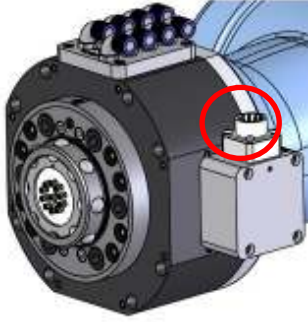

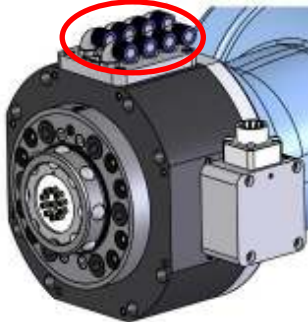

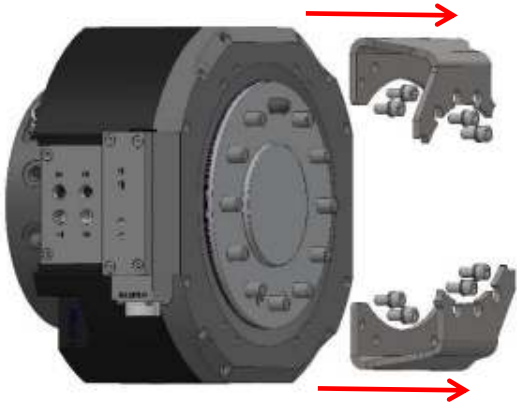
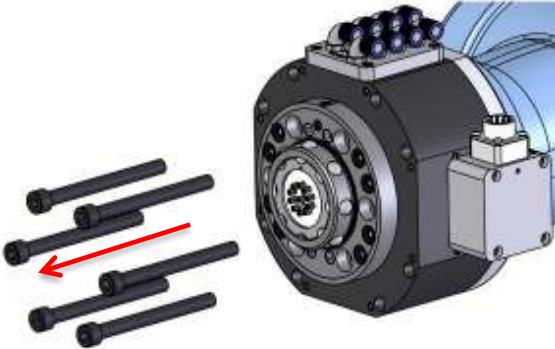
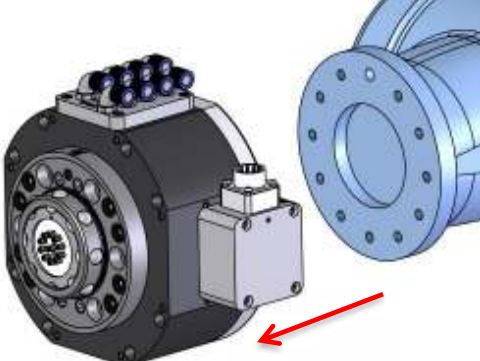
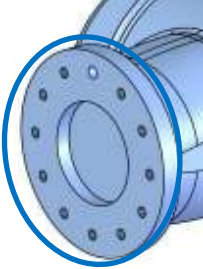
## 4 DISMOUNTING AND REPLACEMENT

### 4.1 Replacement of swivel tool changer

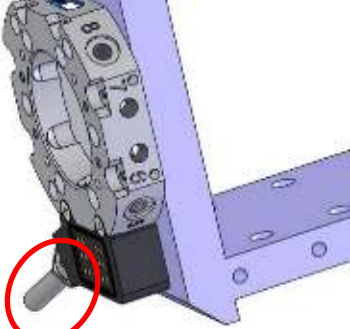
	Action	Note
	<b>1 Safety</b>	Read the safety <a href="#">section 1.2</a> .
	<b>2 Dismount tool</b>	Leave tool, with tool attachment mounted, in tool stand.
	<b>3 Service position</b>	Place the robot in service position. <b>NOTE!</b> The tool change function shall be in locked position.
	<b>4 Power off</b>	Switch the power off and lock the circuit breaker. <b>NOTE!</b> Read the safety chapter for the robot.
	<b>5 Pneumatic air off</b>	<b>NOTE!</b> The pressure in the pneumatic system must be released before dismounting begins.
	<b>6 Disconnect signals (electrical versions only)</b> 	Disconnect electrical connectors.  <b>NOTE!</b> Handle the connectors with care, they are sensitive to mechanical damage. Make sure no dirt enters the connectors.
	<b>6 Dismount air hoses</b> 	Put markings on the air hoses in order to simplify remounting. Dismount the hoses from the swivel tool changer.  <b>NOTE!</b> Make sure that no dirt enters the air hoses.

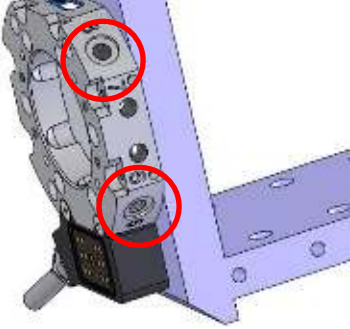
7	<p><b>Remove rotation stop</b></p> 	<p>Release and remove the screws and nuts holding the rotation stop. Remove the rotation stop.</p>
8	<p><b>Remove screws</b></p> 	<p>Remove the fastening screws holding the swivel tool changer.</p> <p><b>WARNING!</b> The swivel tool changer is heavy and may cause damage if dropped.</p> <p><b>NOTE!</b> Be careful not to damage the signal pins at the tool side of the swivel tool changer.</p>
9	<p><b>Dismount swivel tool changer</b></p> 	<p>Dismount the swivel tool changer from the robot flange or, if applicable, the adaptation plate.</p> <p><b>NOTE!</b> A guide pin is mounted between the swivel tool changer and the robot flange.</p>
10	<p><b>Clean the robot flange</b></p> 	<p>Clean the robot flange or, if applicable, the adaptation plate.</p>
11	<p><b>Mount replacement swivel tool changer</b></p>	<p>Follow instructions in <a href="#">section 2.1</a>.</p>

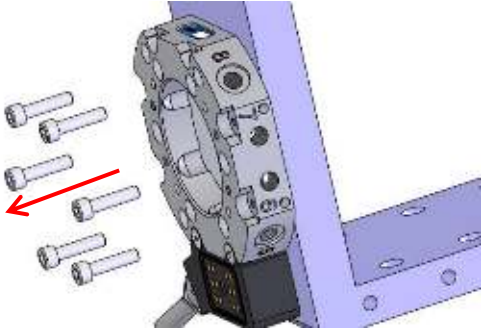
## 4.2 Replacement of tool attachment

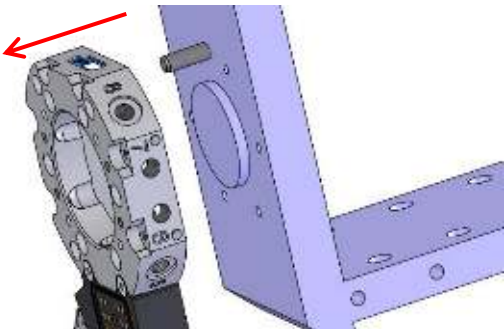
	Action	Note
	<b>1 Safety</b>	Read the <a href="#">safety section 1.2</a> .
	<b>2 Undock tool</b>	Undock tool attachment, with tool mounted, in a safe and fully supported position for dismounting.
	<b>3 Release connections (electrical versions only)</b> 	Disconnect electric power and signals.  <b>NOTE!</b> Handle contacts with care, as they are sensitive to mechanical damage. Make sure that no dirt enters the contacts.
	<b>4 Dismount hoses</b> 	Dismount the air hoses from the tool attachment.  <b>NOTE!</b> Make sure that no dirt enters the air hoses.
	<b>5 Remove screws</b> 	Remove the screws holding the tool attachment to the tool.  <b>WARNING!</b> The tool attachment is heavy and may cause personal injury and equipment damage if dropped.
	<b>6 Dismount tool attachment</b> 	<b>NOTE!</b> A guide pin is mounted between the tool attachment and the tool.
	<b>7 Clean the flange at the tool</b>	
	<b>8 Mount tool attachment</b>	Follow instructions in <a href="#">section 2.2</a> .

## 4.3 Replacement of wear parts

### 4.3.1 Replacement of air sealings

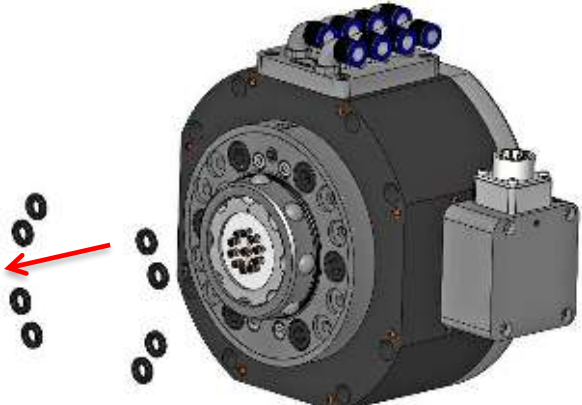
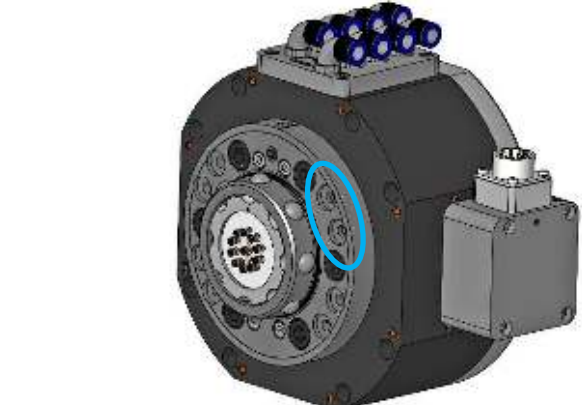
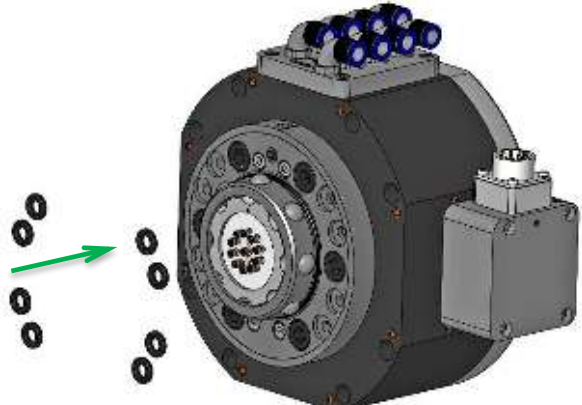
	Action	Note
1	<b>Remove air sealings</b> 	Remove the air sealings with a screw driver.
2	<b>Clean sealing holes</b> 	Wipe clean the sealing holes. Remove all remaining parts of the air sealings.
3	<b>Replace air sealings</b> 	Tap in the new air sealings with a plastic mallet.

### 4.3.2 Replacement of signal pins (electrical versions only)

	Action	Note
1	<b>Power off</b>	Switch the power off and lock the circuit breaker.
2	<b>Remove signal pins</b>	Pull out the signal pins with a pair of pliers..
3	<b>Replace signal pins</b>	Fit the new signal pins by pushing them into the sleeves.  <b>NOTE!</b> The signal pins must be individually pressed fully into the sleeves using a small screw driver!
4	<b>Power on</b>	Unlock the circuit breaker and switch the power on.

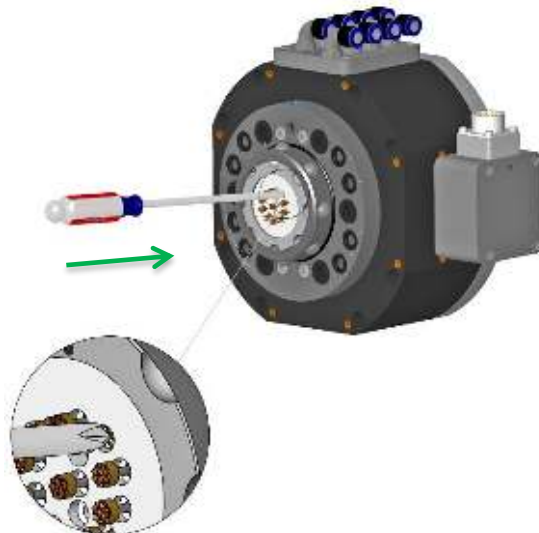
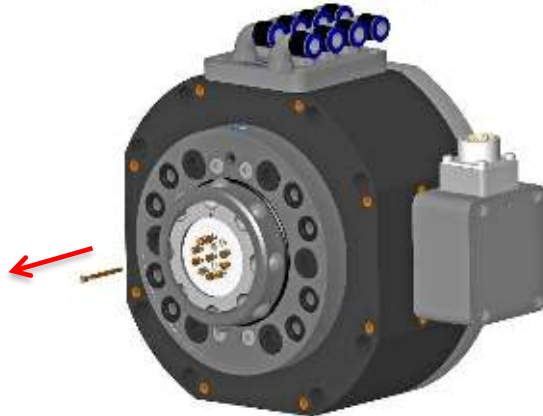

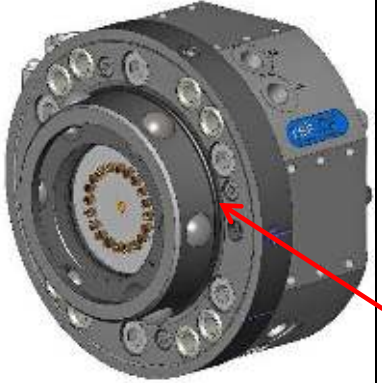

### 4.3.3 Replacement of O-ring (STC100, STC250 and STC350 only)

	Action	Note
1	<b>Remove O-ring</b> 	Remove the O-ring on the ball holder at the swivel tool changer with a screw driver,
2	<b>Clean surface</b>	Clean the surface at the O-ring location.
3	<b>Mount new O-ring</b>	<b>NOTE!</b> Make sure that the O-ring has fully entered the groove surrounding the ball holder.
4	<b>Apply grease</b>	Add a small amount of grease (Magnalube-G) on the new O-ring.



## 5 DISPOSAL AND RECYCLING

### **Taking care of spent equipment**

Used equipment must be taken care of in an environmentally-friendly way.

When disposed of, a major share of the material, or its energy content, can be recycled. The quantities possible to recycle vary depending on technical resources and practises in respective country. Non-recyclable components shall be handed over to an authorized environmental waste treatment facility for destruction or disposal.

### **Electronics**

Electronic equipment shall be sent to an authorized recycling company or sorted into different component materials and treated as such.

### **Metals**

Metals can, in general, be melted down, recycled and used in new products. They shall be sorted according to type and surface coating and handed over to an authorized recycling facility.

Metal components of steel and aluminium are substantial in size and easy to identify. Copper is primarily used in transmission of power for spot welding. Silver or gold plating of contact surfaces may occur.

### **Plastics**

Thermoplastics can, in general, be re-heated and recycled without any major loss of quality. They shall be handed over to an authorized recycling facility. POM occurs in swivel housings, etc. PTFE in some sealings.

### **Rubber**

Rubber shall be handed over to an authorized environmental waste treatment facility either for recycling, disposal or destruction. Rubber occurs in O-rings.

### **Other material**

All other material shall be sorted and handed to an authorized environmental waste treatment facility in accordance with national legislation.



